

| | | | | | | |
|--|--|----------|-----------|------------|-------------|---------|
| UNLESS OTHERWISE SPECIFIED, DIMENSIONS ARE IN MILLIMETERS | | NAME | SIGNATURE | DATE | | |
| ANGULAR = ± ° | | DRAWN | | 2019-05-15 | TITLE | |
| | | CHECKED | | | Tambour Box | |
| | | APPROVED | | | | |
| DO NOT SCALE DRAWING | | | | | | |
| THIRD ANGLE PROJECTION | | MATERIAL | FINISH | | SIZE | DWG NO. |
| | | | | | A4 | 1 |
| | | | | | SCALE | WEIGHT |
| | | | | | 1:3 | |
| | | | | | SHEET | REV. |
| | | | | | 1 of 5 | |

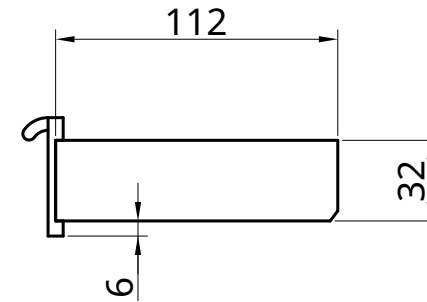

| | | | | | | |
|--|----------|-----------|------------|--|---------------------|-----------------|
| UNLESS OTHERWISE SPECIFIED, DIMENSIONS ARE IN MILLIMETERS ANGULAR = ±° | NAME | SIGNATURE | DATE | TITLE Tambour Box Drawer | | |
| | DRAWN | | 2019-05-15 | | | |
| | CHECKED | | | | | |
| | APPROVED | | | | | |
| DO NOT SCALE DRAWING | | | | | | |
| THIRD ANGLE PROJECTION | MATERIAL | FINISH | | SIZE A4 | DWG NO. 2 | REV. |
| | | | | SCALE 1:3 | WEIGHT | SHEET 2 of 5 |

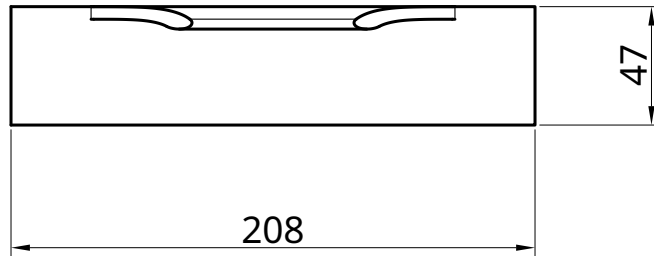
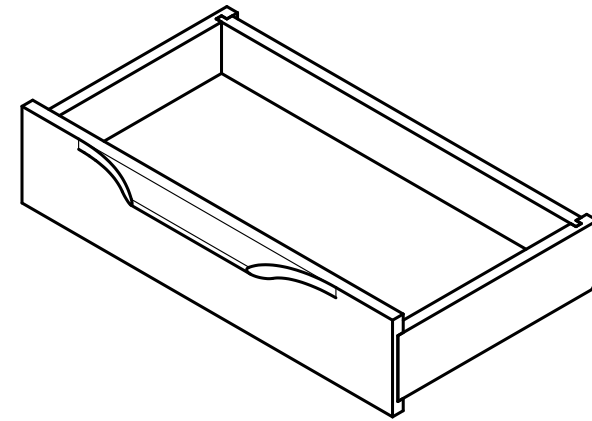
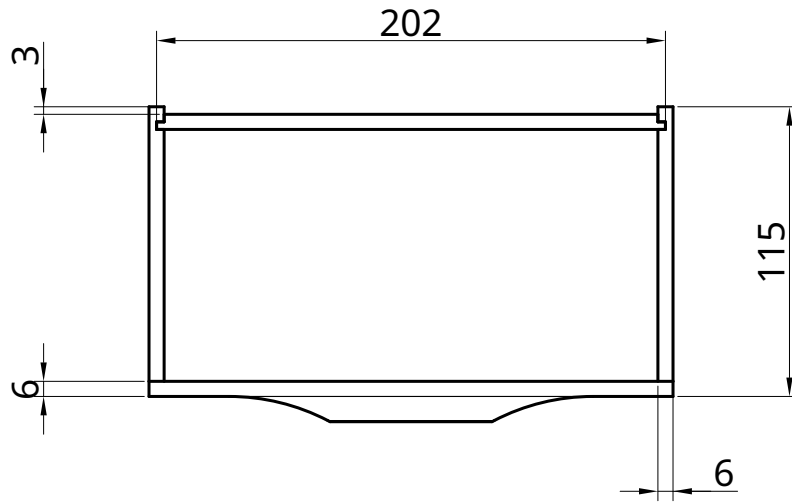
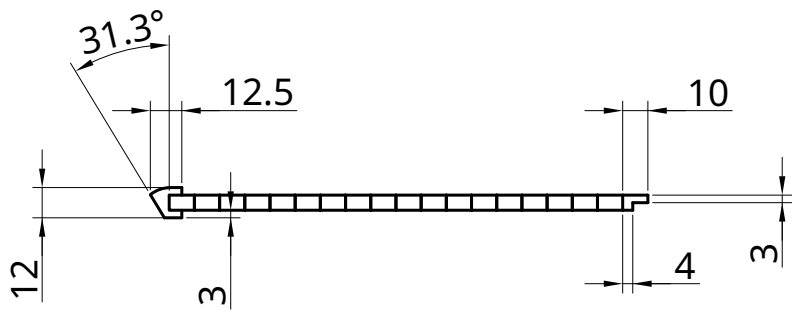
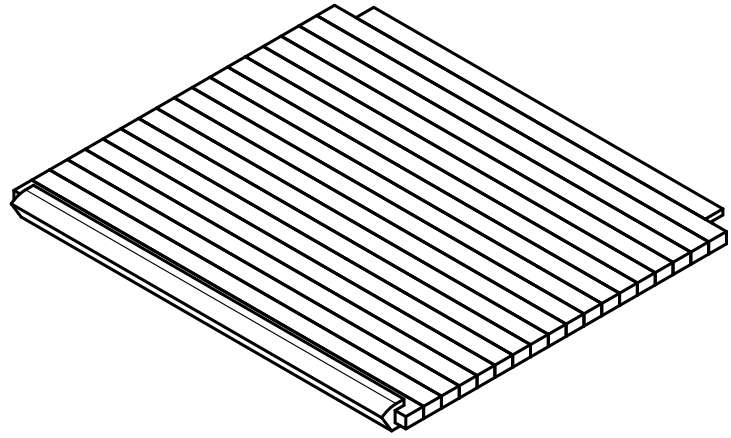
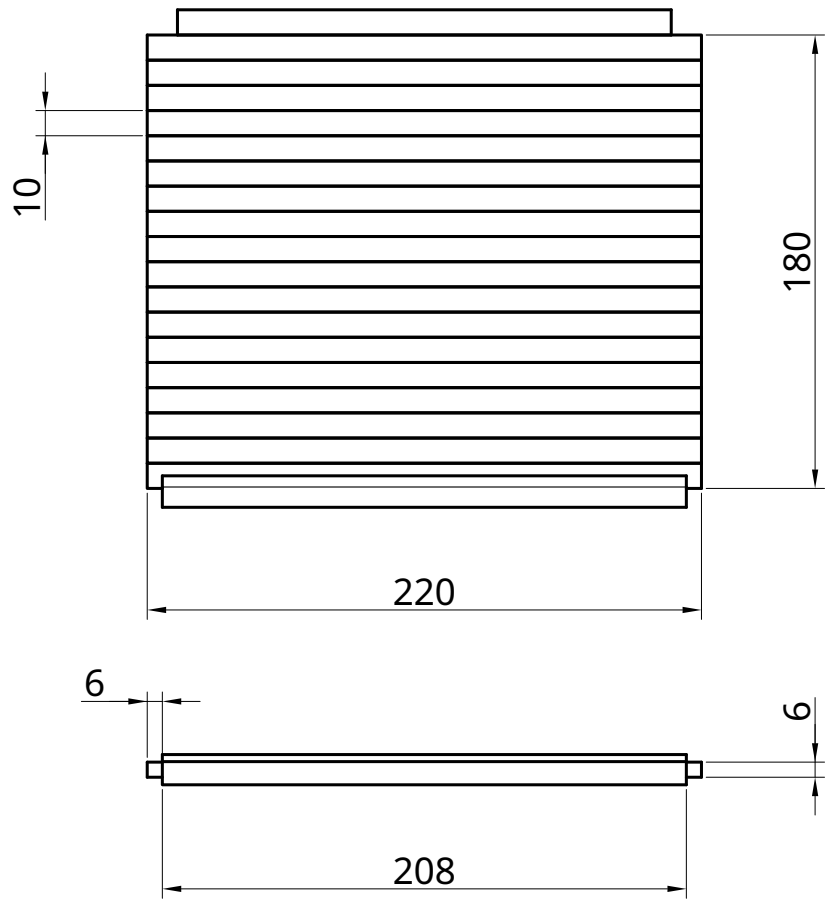

| | | | | | | |
|---|----------|-----------|------------|---------------------------------|---------------------|-----------------|
| UNLESS OTHERWISE SPECIFIED, DIMENSIONS ARE IN MILLIMETERS ANGULAR = ± ° | NAME | SIGNATURE | DATE | TITLE Tambour Top | | |
| | DRAWN | | 2019-05-16 | | | |
| | CHECKED | | | | | |
| | APPROVED | | | | | |
| DO NOT SCALE DRAWING | | | | SIZE A4 | DWG NO. 3 | REV. |
| THIRD ANGLE PROJECTION | MATERIAL | FINISH | | SCALE 1:3 | WEIGHT | SHEET 3 of 5 |
| | | | | | | |



Education

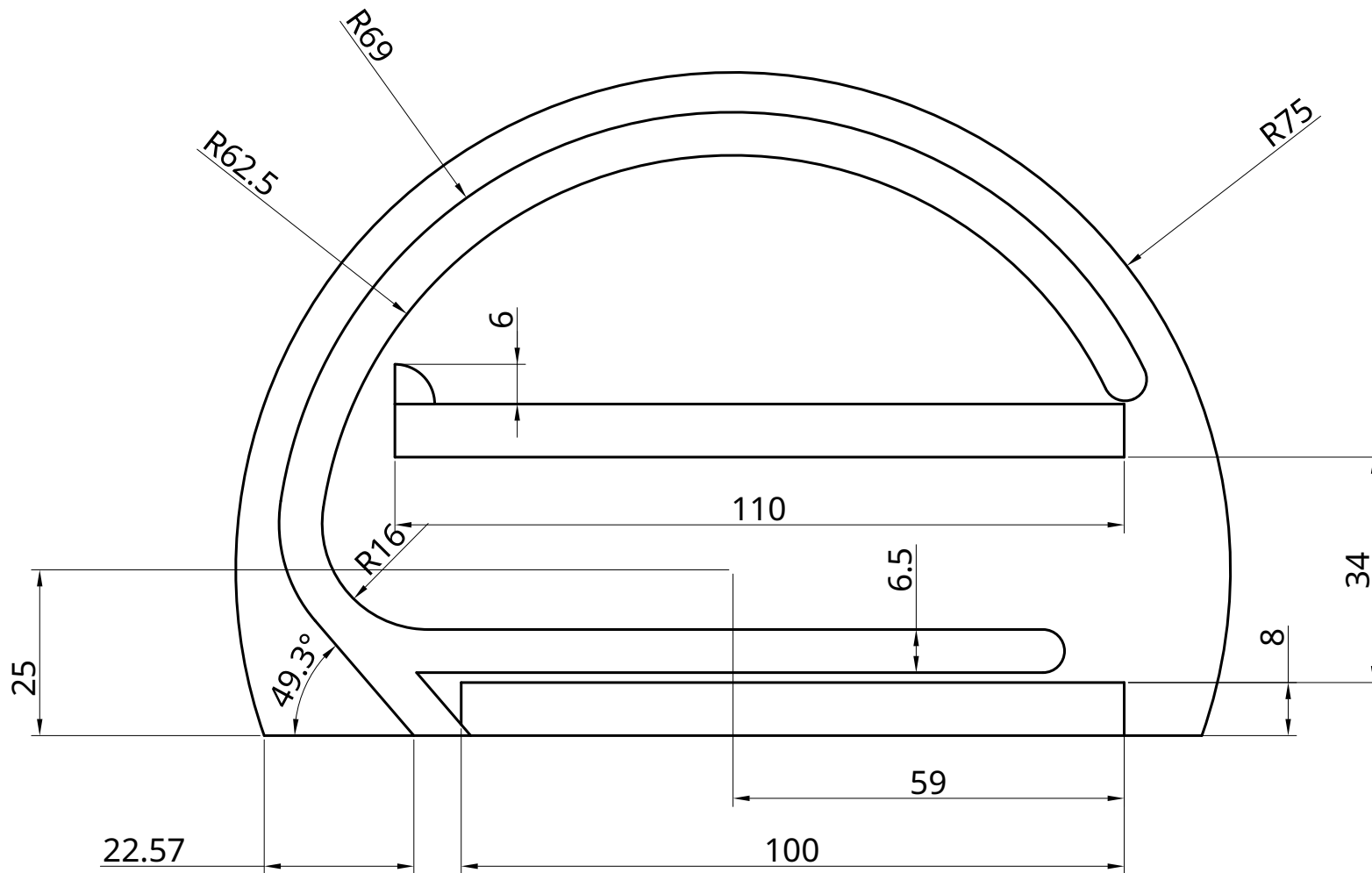

| | | | | |
|---|----------|-----------|------------|--|
| UNLESS OTHERWISE SPECIFIED, DIMENSIONS ARE IN MILLIMETERS ANGULAR = ± ° | NAME | SIGNATURE | DATE | TITLE Box Side Layout with Shelf Locations |
| | DRAWN | | 2019-05-16 | |
| | CHECKED | | | |
| | APPROVED | | | |
| DO NOT SCALE DRAWING | | | | |
| THIRD ANGLE PROJECTION | MATERIAL | FINISH | | SIZE A4 |
| | | | | DWG NO. 4 |
| | | | | SCALE 1:1 |
| | | | | WEIGHT |
| | | | | SHEET 4 of 5 |
| | | | | REV. |



Education

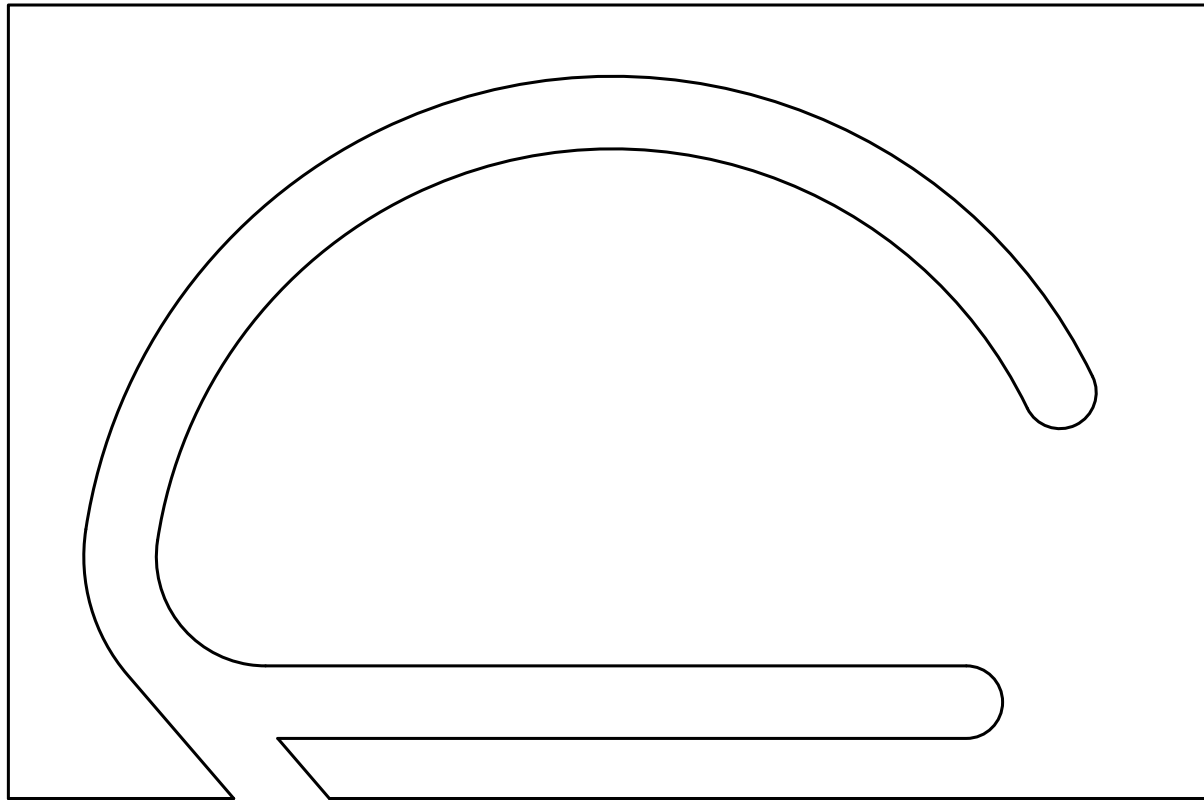

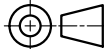
| | | | | | | |
|---|----------|-----------|------------|--------------------------------------|---------------------|------------------------|
| UNLESS OTHERWISE SPECIFIED, DIMENSIONS ARE IN MILLIMETERS ANGULAR = ± ° | NAME | SIGNATURE | DATE | TITLE Routing Template | | |
| | DRAWN | | 2019-05-16 | | | |
| | CHECKED | | | | | |
| | APPROVED | | | | | |
| DO NOT SCALE DRAWING | | | | | | |
| THIRD ANGLE PROJECTION | MATERIAL | FINISH | | SIZE A4 | DWG NO. 5 | REV. |
|  | | | | SCALE 1:1 | WEIGHT | SHEET 5 of 5 |