

# Structured Cabling System Specification

**Information Technology Directorate**

NSW Department of Education

LEVEL 10, 8 CENTRAL AVENUE, SOUTH EVELEIGH, NSW 2015

Version 1.4 – October 2024



# Table of Contents

Table of Contents	1
Document details:	4
Glossary of terms:	4
Revision history:	4
Abbreviations and acronyms:	5
1. Introduction	9
2. Exceptions	10
3. General	10
4. Horizontal cabling specifications	11
4.1 General	12
4.2 Category 6A channel performance	13
4.3 Cat6A cabling construction for pathways	14
4.3.1 External (Underground/Outdoor):	14
4.3.2 Indoor:	14
4.4. Installation	15
4.5 Cabinet pathways	16
4.6 Terminations	16
4.6.1 T568A Pin assignment:	16
4.6.2 Cabinets	16
4.6.3 Telecommunications outlets	17
4.7 Wireless Access Point (WAP) cabling	17
4.7.1 Internal:	18
4.7.2 External:	18
4.8 Security cabling	18
Other systems	19
4.9 Leads/Patch cords	19
4.10 Copper cabling between distributors	19
4.11 Surge Protection Device (SPD)	20
4.12 Labelling	20
4.13 Testing	20
5. Optical fibre cabling specifications	20
5.1 General	20
5.2 Optical Fibre Performance	21
5.3 Optical Fibre Cabling Construction for Pathways	21
5.3.1 Underground:	21
5.3.2 Outdoor:	21
5.3.3 Indoor:	22
5.4 Optical Fibre Installation	22
5.5 Optical Fibre Cabinet Pathways	22

5.6 Optical Fibre Terminations	22
5.7 Optical Fibre Patch Panels (FOBOTS)	23
5.8 Optical Fibre Leads/Patch Cords	23
5.9 Optical Fibre Labelling	24
5.10 Optical Fibre Testing	24
6. Distributor design	24
6.1 Communications rooms – definitions	25
6.1.1 Main Communications Room (MCR contains CD and BD)	25
6.1.2 Building Communications Room (BCR contains BD/FD)	25
6.2 Communication Rooms – Design Principles	25
6.3 Communication Rooms – Locations	26
6.3.1 Main Communications room (MCR contains CD and BD)	26
6.3.2 Building Communications Rooms (BCR contains BD/FD)	26
6.3.4 Single level buildings:	26
6.3.5 Multi-level buildings:	26
6.3.6 Multiple structures under one roof line	27
6.4 Cabinet specifications	27
6.4.1 Outdoor Cabinets	28
6.5 Cabinet Layouts	29
6.5.1 Cable pathways:	29
6.5.2 Cable trays:	29
6.5.3 Optical Fibre Trunking (raceway):	29
7. Pathways	30
7.1 General	30
7.1.1 Campus Backbone Pathways	30
7.1.2 Building Backbone Pathways	32
7.1.3 Horizontal Cabling Pathways	32
8. Earthing	35
9. Demountables	35
10. Capital works/refurbishment/expansions	35
11. Labelling	36
11.1 Cabinet labelling:	36
11.2 Fibre cable labelling:	36
11.3 Horizontal cable labelling in cabinets:	37
11.4 Telephony cable labelling in cabinets:	37
11.5 Telecommunications Outlet labelling:	37
11.5.1 Access points:	38
CCTV Cameras	38
12. Testing	38
12.1 General	38
12.2 Horizontal Cabling	38

12.3 Optical Fibre	39
13. Documentation	39
13.1 As-Installed Drawings	39
13.2 Test Results	40
13.3 Warranties & Certification	40
13.3.1 Site Cabling Warranties	40
13.3.2 Manufacturers Certification	40
13.3.3 Multiple Vendor Certifications	40
13.4 Cabling Checklist	40
Appendix A. Room distributors	41
Appendix B. Rack layout	43
Appendix C. Pathway materials and fixings	45
Appendix D: Fibre examples	47
Fibre Enclosures	47
Fibre connections and patch leads	47
Appendix E: External WAP	48
Appendix F: Patch cable colour chart	50
Appendix G: Conduit and pit diagrams	51
Appendix H: Equipment Sample Approval (ESA) Form	53
Appendix I: Cabling Checklist	55

## Document details:

### Glossary of terms:

Term	Meaning
“Shall”	The term "SHALL" means that the item is an absolute requirement of the standard. Omission of this item from the deployment would mean that the desired objectives would not be met. Objectives include availability, specific functions or technical requirements, and dependent features.
“Shall Not”	The phrase "SHALL NOT", means that the item is absolutely prohibited in the standard.
“May”	“MAY” means that an item is truly optional. For example, you may choose to include the item because a particular objective or application/protocol requires it or because it enhances the deployment.

### Revision history:

Date	Version	Summary of changes	Author
30/10/2024	1.4	<ul style="list-style-type: none"> <li>Standardised on 26AWG for patch leads</li> <li>Further elaborated on where internal vs external cabling can be used</li> <li>Clarification on where a primary BCR will connect back to the MCR vs direct connection to a MCR</li> <li>Updated rack layout for security cabinet in MCR</li> <li>Other minor updates</li> </ul>	Ibrahim Chehab – Network Design
19/09/2022	1.3	<ul style="list-style-type: none"> <li>Updated diagrams</li> <li>Permanent link reduced from 90m to 75m</li> <li>Added section on MPTL for security and other systems</li> <li>Patch leads to be either 23/24AWG or 26AWG</li> <li>Added section on multiple structures under one roof line and the requirement of a comms room per structure</li> <li>Added a section on Outdoor cabinets</li> </ul>	Ibrahim Chehab – Network Design

Date	Version	Summary of changes	Author
		<ul style="list-style-type: none"> <li>Cabling checklist broken into pre-installation and post-installation checklist</li> <li>Added section addressing equipment storage in communications rooms.</li> <li>Copy edit to reflect glossary of terms (See above).</li> </ul>	
01/07/2020	1.2	<ul style="list-style-type: none"> <li>Change from F/UTP to U/FTP for horizontal cabling.</li> <li>Racks in the MCR/BCR changed from 42RU to 45RU and also changed from 900mm to 800mm deep for the BCR racks</li> <li>Rack layout in MCR changed with the BD/School Server and Security/Telephone cabinets swapping locations</li> <li>Added a section on exceptions</li> <li>FOBOT in MCR changed from minimum 72 to 48 port capacity</li> <li>Modified wording for WAP outlets in ceilings i.e. not permitted</li> <li>Added/Updated diagrams</li> <li>Updated standards reference where applicable</li> </ul>	Ibrahim Chehab - Network Design

### Abbreviations and acronyms:

Acronym	Meaning
8P8C	8 Position 8 Conductor modular plug
ACMA	Australian Communications and Media Authority
AMS	Asset Management System
AS/NZS	Australian and New Zealand Standard
AXT	Alien Crosstalk
AWG	American Wire Gauge, Imperial unit used to specify electrical conductor size
BCA	Building Code of Australia
BCR	Building Communications Room

<b>Acronym</b>	<b>Meaning</b>
BD	Building Distributor
BEP	Building Entry Point
BMS	Building Management System
CCTV	Closed Circuit Television
CD	Campus Distributor
CP	Consolidation Point
DAC	Direct Attached Cable
DGPO	Dual General Purpose Outlet
DoE	Department of Education - NSW
DTO	Dual Telecommunications Outlet
EFSG	Educational Facilities Standards and Guidelines - NSW
EMS	Environmental Monitoring System
EPR	Earth Potential Rise
FD	Floor Distributor
FFL	Finished Floor Level
FOBOT	FOBOT Fibre Optic Break Out Termination enclosure
F/UTP	Foil over Unshielded Twisted Pair, where the twisted pairs are encased in an overall foil shield
Gbps	Gigabits per second
GPO	General Purpose Outlet
HV	High Voltage, greater than 1000V AC
ICT	Information and Communications Technology
IDC	Insulation Displacement Connector
IEEE	Institute of Electrical and Electronics Engineers
IoT	Internet of Things
IP	Internet Protocol
ITD	Information Technology Directorate
KVM	A hardware device that allows a user to control multiple computers from one or more sets of keyboards, video monitors and mice

<b>Acronym</b>	<b>Meaning</b>
LAN	Local Area Network
LC	Lucent Connector - a small form factor optic fibre connector
LSZH	Low Smoke Zero Halogen
LV	Low Voltage, exceeding 50V AC and below 1000V AC
MCR	Main Communications Room (also referred to as the CD)
MDF	Main Distribution Frame
MMOF	Multi-Mode Optical Fibre
MPTL	Modular Plug Terminated Link
MUTO	Multi-User Telecommunications Outlet
OTDR	Optical Time Domain Reflectometer
PABX	Private Automatic Branch Exchange
PIR	Power Insertion Loss
PM	Project Manager
POE	Power Over Ethernet
PVC	Polyvinyl chloride
RJ-45	Refer to 8P8C
RU	RU Rack Unit, the unit of measurement is 44.25mm
SCSS	Structured Cabling System Specification
SFP	Small Form Factor Pluggable
SMOF	Single Mode Optical Fibre
SNR	Signal to Noise Ratio
SNSDA	School Network Solution Design Authority
SPD	Surge Protection Device
STO	Single Telecommunications Outlet
STP	Shielded Twisted Pair
TO	Telecommunications Outlet
TRC	Telecommunications Reference Conductor
TTO	Triple Telecommunications Outlet
UPS	Uninterruptible Power Supply

<b>Acronym</b>	<b>Meaning</b>
UTP	Unshielded Twisted Pair
U/FTP	Unshielded Foiled Twisted Pair, where each pair of cables is twisted and wrapped with metal foil
VoIP	Voice over IP
WAN	Wide Area Network
WAP	Wireless Access Point (also referred to as AP)
WLAN	Wireless Local Area Network

## 1. Introduction

The Structured Cabling System Specifications (SCSS) play a critical role in providing the underlying platform for which ICT services for NSW schools are provisioned. It is essential that the cabling infrastructure installed in any NSW Department of Education (DoE) site supports current, as well as future requirements. Implementation of cabling infrastructure needs to be flexible to allow relocations, additions, and changes with minimal impact to existing services and users.

To provide consistency, it is essential that DoE stakeholders are engaged from the initial project concept planning as this may impact existing or new cabling infrastructure.

All cabling infrastructure supplied and installed shall comply with this specification as well as all relevant Australian standards, these include (but are not limited to) the following:

<b>Standard:</b>	<b>Applies to/for:</b>
AS/NZS11801: Current Edition	Part 1: General requirements Part 2: Office Premises Part 3: Industrial Premises Part 5: Data Centres Part 6: Distributed building services
AS/NZS 3084: Current Edition	Telecommunications installations – Telecommunications pathways and spaces for commercial buildings
AS/NZS 3085.1: Current Edition	Telecommunications installations – Administration of communications cabling systems – Basic requirements
AS/NZS 2967: Current Edition	Optical fibre communication cabling systems safety
ISO/IEC 14763-2	Implementation and operation of customer premises cabling Part 2: Planning and installation
AS/NZS 14763.3: Current Edition	Telecommunications installations - Implementation and operation of customer premises cabling - Testing of optical fibre cabling
AS/NZS 61935.1: Current Edition	Testing of balanced communication cabling in accordance with ISO/IEC 11801
AS/NZS IEC 61935.2: Current Edition	Testing of balanced communication cabling in accordance with ISO/IEC 11801 Part 2: Patch cords and work area cords
AS 30129: Current Version	Telecommunications bonding networks for buildings and other structures
AS/ACIF S008: Current Edition	Requirements for authorized cabling products
AS/ACIF S009: Current Edition	Installation requirements for customer cabling (wiring rules)

It is expected that any entity supplying and/or installing cabling infrastructure shall have access to, and abide by the above-mentioned standards. Only cabling systems offering the appropriate warranty/certification by the manufacturer shall be used. The minimum accepted period of certification is twenty (20) years.

The Information Technology Directorate's (ITD) Network Design team, a part of ITD's Infrastructure Services division, is responsible for the maintenance and content of this document. Any proposed alteration to this document shall be reported to the Network Design team for consideration.

General inquiries can be made via:

**Network Design Team, Infrastructure Services, ITD** - email:

[ITInfraServNetworksArchitecture@det.nsw.edu.au](mailto:ITInfraServNetworksArchitecture@det.nsw.edu.au)

The School Network Solution Design Authority (SNSDA), is an ITD working group consisting of representatives from different ITD teams that evaluate and provide advice in relation to network related activities at school sites. Any requests for exceptions, shall be made to the SNSDA for consideration. Please contact:

**DoE School Network Solution Design Authority** - email: [SNSDA@det.nsw.edu.au](mailto:SNSDA@det.nsw.edu.au)

## 2. Exceptions

All cabling works shall comply with the requirements set out in this specification. Where this is not possible, an exception shall be required to be raised with the SNSDA for it to be evaluated. Approval from the SNSDA is required prior to the commencement of the works in question.

It is recognised that some spaces have installation constraints such as heritage, hazard, or architectural aesthetic considerations – all such factors need to be evaluated and direction sought from ITD. All requests for exceptions shall be directed via the SNSDA [Email: SNSDA@det.nsw.edu.au](mailto:SNSDA@det.nsw.edu.au) (Please note, DoE staff can request an exception via the [SNSDA SharePoint site](#). Requests for exemption will be considered at the next available SNSDA meeting).

Exceptions shall only be approved if they are reasonable – i.e. a 45 RU rack will not fit in the proposed location and the request shall use a 27RU rack instead. Any requests to deviate from regulatory compliance shall not be approved.

## 3. General

All participants in infrastructure implementation shall comply with the requirements of both the specific initiative and all government rules and regulations. Whilst all efforts will be made by NSW DoE to provide relevant requirements, it shall be the responsibility of the participants to make representation to the authorised persons and/or authorities to ensure they are informed of all requirements.

Requirements may include:

- Clothing and [personal protective equipment \(PPE\)](#) - for safety and identification.
- [Licensing](#) – for electrical and telecommunications cabling.
- Scheduling – co-ordination of works to suit business practices.
- Working in Schools – specific [child protection rules](#) and [Work Health and Safety \(WH&S\)](#).
- Cleanliness – removal of packaging and building waste, and the use of drop sheets to protect DoE property.
- [Working at heights](#) – safety equipment as required by [SafeWork NSW](#) .
- [Noise](#) – coordinating building works to minimise noise impact during school hours

- [Working with Asbestos](#) – perform the actions required when working with asbestos.

All contractors engaged by DoE to carry out work in schools shall obtain clearance for entering premises where children are located. All non-DoE staff shall follow the department's requirements for work clearance as determined by the Principal before commencing work on a site.

Entities within DoE are Schedule 1 customers and are directed by the Department of Premier and Cabinet to use contractors on the current ICT Services Prequalification Scheme or its replacement. Contractors are required to be an approved [registered supplier on the ICT Service Scheme](#) 0020 for [Category F02 – Network Management – Network Operations including delivery “as a service”](#).

The contractor shall:

- ensure that during the entire period of works at least one cabler is onsite and hold an ACMA Open registration with endorsements for each cable plant being installed or worked on;
- provide a copy of this standard to the sub-contractor, where cabling work is being sub-contracted by the primary contractor;
- remain responsible for ensuring that all installation works are fully compliant with this specification;
- be accredited with the manufacturer (of the cabling being used on site) as an approved installer prior to the works commencing;
- make all the necessary inquiries of all relevant authorities (including DoE) and perform all relevant testing to ensure that works being performed under their contract will not disrupt other services (Examples include contacting “Dial before you dig” to check if there are underground broadband, electrical, gas, water, waste and other services and performing traces of cables and conduits);
- check the latest school asbestos register and plan accordingly;
- ensure that their Public Liability insurance (or other) will cover the costs of reinstatement associated with any disruption of services.

Should the contractor disrupt any service during their work, they shall make all efforts possible to rectify the service in the least amount of time possible. Where damage to the service is major and substantial, a replacement of that service must be undertaken at a time suitable to the department. The replacement shall be according to the latest specification set out in this document, for e.g. if a 6 core OM1 fibre is damaged, then the contractor must replace it with a 12 core OS2 fibre. The contractor is responsible for the costs and coordination of the rectification, and replacement of the service(s).

Before commencing any works, the Pre-Installation checklist in Appendix I: Cabling Checklist shall be completed by the contractor, DoE project manager and external project manager (if applicable).

## 4. Horizontal cabling specifications

Important:

- **Greenfield sites** are defined as buildings, sites or floors where NSW DoE has no existing telecommunications infrastructure (cabling, LAN or WAN), e.g. Schools Infrastructure projects for new and expanded sites.

- **Brownfield sites** are defined as buildings, sites or floors where NSW DoE has existing telecommunications infrastructure in place (cabling, LAN or WAN), e.g. schools infrastructure refurbishment projects.

**NOTE:** Where existing telecommunication infrastructure is being removed and replaced (i.e. communication rack and cabling as part of a capital works program) then this shall be classified as a Greenfield site.

The Category 6A (Cat6A) specified for installation at **Greenfield sites** shall be:

- Category 6A/ClassEA, U/FTP, LSZH, Indoor or Plenum grade for internal.
- Category 6A/ClassEA, U/FTP, Outdoor grade for external.
- Submitted for approval, before installation using the form in Appendix H: Equipment Sample Approval (ESA) Form.

This is a shielded cable system and all connected components (RJ45 jacks, patch leads etc.) shall be shielded. Refer to section 8. Earthing. Category 6A/Class EA, U/FTP may be substituted with F/UTP if U/FTP is not available.

The Category 6A (Cat6A) specified for installation at **Brownfield sites** shall be:

- Category 6A/ClassEA, U/UTP, LSZH, Indoor or Plenum grade for internal.
- Category 6A/ClassEA, U/UTP, Outdoor grade for external.
- Submitted for approval, before installation using the form in Appendix H: Equipment Sample Approval (ESA) Form.

The U/UTP cable **shall** have a metallic/aluminium foil that wraps around the outer cable or around the pairs of the cable.

All internal grade CAT6A cabling (regardless of the type) shall have a Low Smoke Zero Halogen sheath.

All further references to Cat6A cabling in this document refer to the above specifications.

For clarification about whether a site is classified as either Greenfield or Brownfield, the contractor or DoE project manager shall send a request to the SNSDA for determination. It is imperative that this is done before any works commence.

#### 4.1 General

The horizontal data cabling system shall consist of:

- Only Category 6A horizontal cabling;
- Cable trays as the major cable support systems;
- Patch panels and cable management;
- Testing and commissioning;
- As built documentation;
- Manufacturer certification;
- Appropriate labelling.

Where specified, cabling to each outlet shall consist of pairs per outlet as outlined in the table below:

Outlet type:	Number of 4 pair CAT6A cables to each RJ45 outlet:
Single (STO)	1

Outlet type:	Number of 4 pair CAT6A cables to each RJ45 outlet:
Dual (DTO)	2
Triple (TTO)	3

- Cable installation shall be in accordance with Australian standards and manufacturers guidelines.
- For greenfield sites, all horizontal cabling shall be completed by the one contractor. It shall be consistent across the site and warranted as a single cabling solution by the manufacturer, regardless if it is used for data, security, BMS or any other service.
- All underground external grade cabling shall require surge protection to be installed at the Distributor end of the cable.
- Outdoor rated gel filled cables shall be installed for any cable that exits the building (whether it be via under covered walkways or underground, in conduit or otherwise);
- The Cat6A System shall be fully grounded and bonded as per the relevant standards - AS/CA S009, TIA942, TIA/EIA J-STD-607-A and J-STD-607A. See section 8. Earthing.
- All Wireless Access Points shall be allocated dual outlets.
- All horizontal cabling shall be installed via dedicated communications cable trays and pathways at all times.
- Each run of cable from the Building or Floor Distributor to the Telecommunications Outlet shall be contiguous without any joints or splices.
- All horizontal cabling shall connect to a Building Distributor on the same floor, unless explicit permission has been given by the SNSDA.
- Bundle sizes shall be limited to a maximum of 24 cables per bundle and bundles shall not be stacked or packed tightly. This is to ensure efficient deployments and allow the potential for future services relocation.
- Cable bending radii shall be observed at all times, kinks, crushed and tight bends shall not be accepted.

Please note:

- The use of plastic cable ties for installations is strictly prohibited.
- The installation of Consolidation Points is strictly prohibited.

#### 4.2 Category 6A channel performance

- The Category 6A U/FUTP structured cabling solution shall be installed to class EA standards, ensuring a frequency of 500Mhz and shall be comprised of category 6A components capable of providing 10 Gigabit Ethernet operations using full-duplex transmissions.
- Although standards state that the maximum permanent link is at 90 meters, this recommendation assumes an ambient temperature of 20 degrees Celsius. Taking into consideration the high likelihood of temperatures in NSW exceeding 20 degrees Celsius (as well as other factors such as PoE heat rise), the maximum permanent link length for LAN design purposes shall be set to **75 meters**. Any exceptions to this rule shall be approved by the SNSDA.

### 4.3 Cat6A cabling construction for pathways

There are two (2) classifications of Cat6A cabling to be used, based on the cabling's installation pathways; **External** and **Indoor**.

#### 4.3.1 External (Underground/Outdoor):

Cat6A cables that are installed with any portion of its cable:

- in underground conduits and/or;
- exposed to the elements and/or;
- in protected (i.e. either conduit or ducting or other) above ground outdoor and/or;
- In adverse internal pathways;

Shall be classified as **“External” and external grade Cat6A shall be installed**. Surge protection shall also required. See section 4.11 Surge Protection Device (SPD).

#### 4.3.2 Indoor:

Cat6A cables that are installed wholly within internal building spaces such as;

- Riser cupboards;
- Internal ceiling cavities;
- Internal wall cavities;

Shall be classified as **“Indoor” or plenum grade as required**. Indoor cabling shall, in addition, consist of low smoke zero halogen sheathing.

NOTE: where devices such as WAP's, security and BMS equipment amongst others, are mounted on the outside of a building and fed from inside the building, without any portion of the cable in any conduit or ducting, then internal grade cabling can be used (see Installation Example A in Figure 1). Where the device has any length of conduit or ducting used to get to the outlets final position, then external grade cable shall be used (see Installation Example B in Figure B):

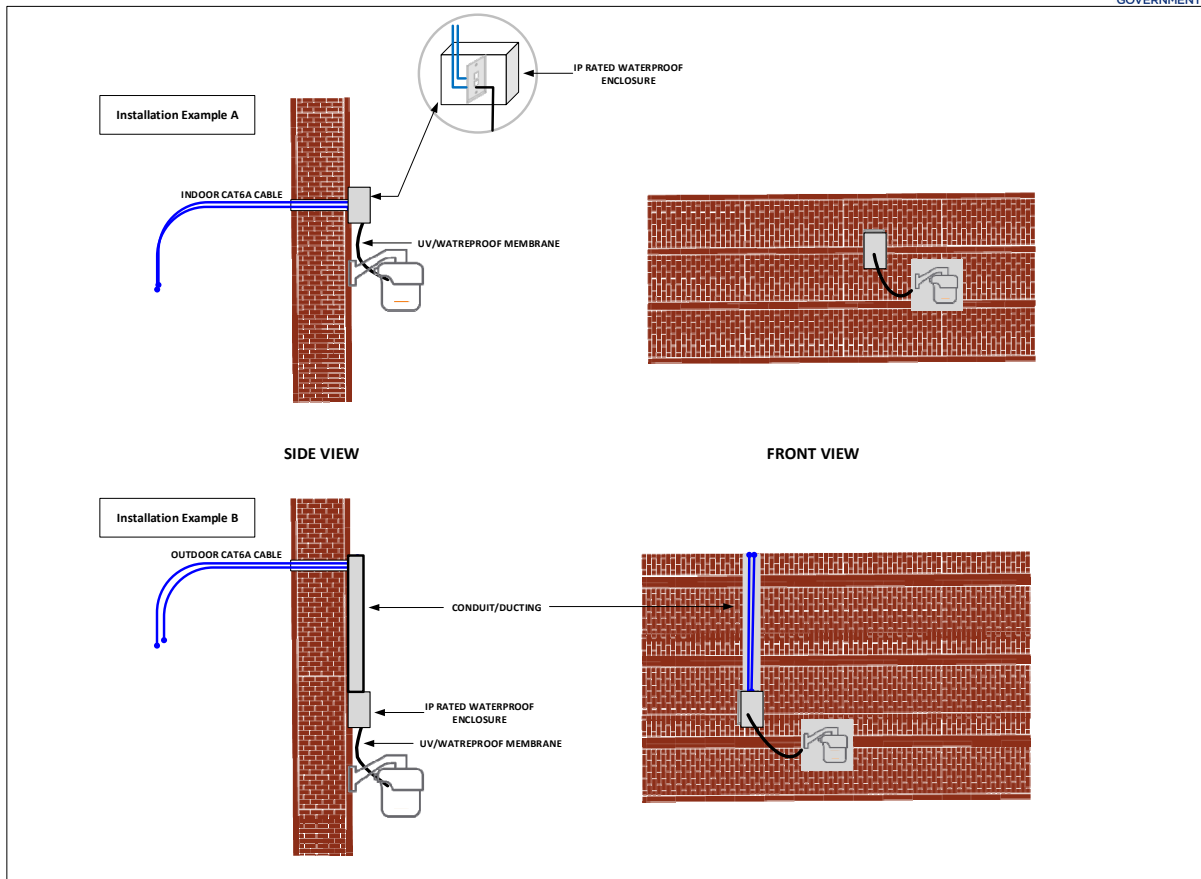

Figure 1 – Internal vs External cabling

#### 4.4. Installation

The following installation techniques shall apply:

- Pulling tension shall not exceed the manufactures specifications for all cabling installed.
- If the physical cable sheath is seen to be damaged or of inferior manufacture, e.g. cable twists, uneven sheath shape and the like, the reel shall be set aside and replaced.

If defects inspections reveal damaged or inferior manufactured cable, the complete run shall be replaced at no additional cost.

- Bending radii shall not exceed the manufactures specifications for all cabling either during installation or in its final location.

Apart from the approved pathways listed in sections 6 and 7, all horizontal cabling shall be installed via dedicated communications cable trays at all times.

All cabling shall enter cavity walls from the ceiling space where appropriate for new buildings and where possible in existing buildings. Cables dropped from cable trays or other cable support systems shall be neatly loomed and secured with hook and loop, e.g. Velcro or approved cable support mechanisms which shall be used along the entire length of the cable pathway.

The use of plastic cable ties for installations is strictly prohibited.

## 4.5 Cabinet pathways

In new installations, horizontal cabling shall be carried in cable trays mounted above the cabinet, entering the cabinet through a designated corner entry point. Cabling shall not enter through the cabinet floor, front, rear or side panels. Variations shall require approval from the SNSDA. Horizontal cabling shall be run down the sides of the rack, using the designated cable tray that is part of the rack.

A minimum 1.5M service loop shall be maintained for each cable installed. The service loop shall be stored in the cable tray, ceiling space or cabinet in a neat manageable manner.

## 4.6 Terminations

The telecommunications outlet pin assignment shall be identical to the existing methodology utilised on site. For installations where no existing horizontal cabling exists, the outlet pin assignment shall adhere to T568A.

A single, consistent PIN assignment shall be adopted throughout the installation.

### 4.6.1 T568A Pin assignment:

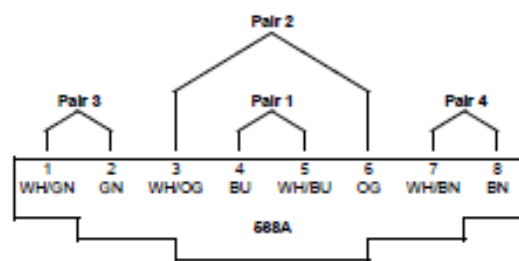

Figure 2 - T568A Pin assignment

### 4.6.2 Cabinets

- All patch panels shall be rack mounted RJ45 panels with 24 ports being 1RU in height. The ports shall be aligned with the mounting rails. If recessed or protruding panels are used, enough clearance shall be provided for the door to be closed when patch cables are installed. Angled V style patch panels are prohibited. Patch panel categories shall be consistent throughout the whole site and are not to be mixed. The patch panels shall have a provision for labelling. See section 11. Labelling.
- Patch panels shall be installed and identified with a unique outlet numbering sequence that is continuous across the entire installation. See section 11. Labelling.
- Service loops or any excess cabling shall not be stored in the cabinet unless it is done in a neat and manageable manner.
- Terminations and termination procedures shall comply with local and international standards as well as the manufacturer recommendations for certification compliance. Only the minimum length of the cable jacket required for termination shall be removed.
- The untwisted length in any cable element shall be as short as possible.
- Horizontal cables shall be used with connecting hardware and patch cords, or jumpers, of the same performance category or higher to maintain a manufacturer certifiable channel performance.

- The overall system performance levels shall be classified by the least performing component in the link.

#### 4.6.3 Telecommunications outlets

- Telecommunications outlets may be reticulated from the ceiling space, floor space or in internal wall conduits, whichever is applicable.
- NSW DoE has strict requirements on the types of telecommunications outlets permitted to be installed. This covers the RJ-45 jack itself and also the wall plate/covers that houses the jack.

Each component shall be submitted for approval **before installation** using the Appendix H: Equipment Sample Approval (ESA) Form.

The RJ45 jack shall:

- be installed with a fixed mechanism that is self-closing and covers the contacts within the jack when not in use;
- be matched to the cabling being installed to provide full manufactures warranty;
- be matched to the horizontal cabling type specified in 4. Horizontal cabling specifications;
- be submitted for approval, before installation using the Appendix H: Equipment Sample Approval (ESA) Form.

The wall plate housing the RJ45 jack shall:

- be fitted with a tamperproof wall plate that requires the use of a tool to remove. Any panel, facia or any component that is an integrated part of the jack and labelling shall not be removable without the use of a tool.
- Have adequate space for the required labelling to be installed as per section 11. Labelling. Where there is labelling on the surrounding edge plate or clip on cover then the use of a tool to remove this component is required i.e. clip on covers or components that can be removed by hand and have labelling on them are not permitted.
- Be submitted for approval, before installation using the Appendix H: Equipment Sample Approval (ESA) Form.

Where the RJ45 jack does not have a fixed self-closing shuttered mechanism, then a shuttered bezel that is between the RJ45 jack and the wall plate may be used, provided it has been approved by using the Appendix H: Equipment Sample Approval (ESA) Form.

Note: Shuttered outlets are not required on the patch panel end in communication rooms.

#### 4.7 Wireless Access Point (WAP) cabling

All Wireless Access Points (WAPs) shall be allocated one dual outlet per WAP.

The distance between the outlet and the final mounting place for the WAP shall not exceed 30cm for both wall mounted and ceiling mounted outlets. The outlets shall be visible at all times and **SHALL NOT** to be concealed in the ceiling or wall cavities.

The WAP, regardless of being internal or external, shall be visible at all times. If required, a protective enclosure for internal WAPs may be considered in suitable locations (e.g., halls gymnasiums, indoor pools). All requests for enclosures shall be discussed with the DoE ITD representative.

If requested, a DoE ITD representative shall inspect proposed locations of the WAP

cabling prior to sheeting.

#### 4.7.1 Internal:

For new cabling and WAP installations, if the ceiling height is above 3m, or the ceiling surface is unsuitable (e.g. metal), WAPs shall be wall mounted at 2.4m above finished floor level (FFL), nearest the centre of the room with allowance given for a 1m clearance radius that is free from interference (from ceiling fans, lights, sensors, speakers etc.).

To ensure minimal and unnecessary co-channel interference (which can lead to performance and stability degradation), there shall be adequate separation between all WAPs. The following tolerance guidelines shall be applied to a wireless network design. All WAPs shall be provided with;

- a minimum of 6m separation when there is 1 common wall or spaces without an adjoining portal or opening i.e. shutters, curtains or blinds.
- a minimum of 4m separation when there are 2 or more common walls/hallway.
- a minimum of at least 12m separation when there are 2 or more WAPs mounted within one continual open space i.e. Libraries or Halls.

NOTE: Any exceptions to the rules above shall be raised with the SNSDA for evaluation and approval.

#### 4.7.2 External:

External WAPs shall include waterproof outlet covers.

The associated patching cable shall be externally rated and protected by a UV and waterproof membrane, securely connected and routed in a manner that encourages water to not pool on any of the related components. This water proofing shall be consistent with the IP66 and IP67 protection of the access points. Refer to Appendix E: External WAP

External WAPs shall be installed between 2.7m and 4m from ground level (FGL) to allow for troubleshooting and serviceability. A 1m radius, free from interference from active equipment (lights, speakers, security cameras etc.) shall be provided around the WAP.

Please note that the above requirement does not apply to point-to-point wireless bridges. Where possible and practicable, the DTO for an external WAP may be installed on the inside wall, provided that is within 1 meter of the WAP, is accessible to DoE staff and does not hinder the aesthetics of the wall.

All outlets, internally or externally mounted, shall be terminated onto an approved wall plate and not left hanging.

See the example shown in Appendix E: External WAP.

### 4.8 Security cabling

All cabling for IP based security devices (including, but not limited to, security cameras, alarms, intercoms, etc.) shall adhere to the specifications as set out in 4. Horizontal cabling specifications (Cat6A shielded cabling).

Security cabling shall be concealed to prevent tampering, and where the cabling cannot be terminated into a standard 8P8C modular jack, shall be terminated using MPTL connectors. MPTL connectors shall be tested as per AS/NZS 11801-1 and shall be covered by manufacturer's warranty. In Greenfield sites, all security cabling shall be completed by the same contractor as the data cabling, this allows for a single certified cabling solution throughout the site.

All security systems require Departmental approval prior to installation, schools shall contact the Department's School Security Unit (SSU) for guidelines and advice before installing any security related devices such as CCTV, Intercoms, Alarms etc. All IP based security systems are to connect to DoE managed network equipment, no parallel networks are permitted.

### Other systems

All equipment installed for, but not limited to, services such as BMS, EMS, AV and PA shall be terminated on a standard wall outlet that is adjacent to the device being installed. All IP based systems are to connect to DoE managed network equipment, no parallel networks are permitted.

Direct connection between the device and the network switch is strictly forbidden, all connections shall be between the wall outlet and the patch panel. Any exceptions shall be raised with the SNSDA for evaluation and approval before cabling has commenced.

Any equipment required for the above systems shall be discussed with and approved by:

- the DoE project manager or the SNSDA team.

Where there is an operational requirement to have a user interface to perform regular tasks then this equipment shall be installed in the school administration office or other suitable location. Access to the MCRs/BCRs is restricted to DoE ICT Support personnel and approved contractors only.

In Greenfield sites all cabling for, but not limited to, services such as BMS, EMS, AV and PA shall be completed by the same contractor as the data cabling, this allows for a single certified cabling solution throughout the site.

### 4.9 Leads/Patch cords

The contractor shall be responsible for the supply and installation of the Category 6A patch leads. Two (2) shielded patch cords/leads shall be provided for every outlet installed, one at the device end and one at the patch panel end.

An additional lead shall be supplied for each surge protection port installed (See section 4.11 Surge Protection Device (SPD)).

Externally mounted device patch leads (e.g. WAPs) shall require an external grade cable at the device end (See Appendix E: External WAP).

The length of the patch cords/leads shall be specified by the ITD representative, as well as the gauge of the patch leads supplied.

The colour of the patch cords/leads shall comply with the Patch Lead Colour Chart (refer to Appendix F: Patch cable). Where the environmental/aesthetics surroundings of a space are better suited to use a different patch cord colour (i.e. WAP mounted onto a black ceiling, a black patch cord is used) then it is suitable to use such coloured patch leads at the device end only.

Please note that 26 AWG patch leads shall be used at both the patch panel end and the device end.. See the example shown in Appendix F: Patch cable.

Any exceptions to the rules above shall be raised with the SNSDA for evaluation and approval.

### 4.10 Copper cabling between distributors

Copper cabling between distributors for data services is strongly discouraged, all data services that run over the DoE network shall use the fibre network. Any requests for

copper cabling between distributors for data services shall be raised with the SNSDA.

Where an exception has been granted for copper cabling between distributors, all inter-building copper backbone cables shall:

- be of outdoor cable construction;
- be gel filled to prevent the ingress of moisture and impurities and;
- meet the specifications as outlined in AS/CA S008.

Where the distance between distributors is over 90 meters, fibre data services shall be utilised.

Any cabling for voice services (non-VoIP) shall be discussed with the DoE project manager. There may be a requirement for some Cat3 voice cabling between distributors (usually a 25 pair), but this shall be confirmed with the DoE project manager before any works commence.

#### 4.11 Surge Protection Device (SPD)

Where external twisted pair cabling is installed with any portion of it underground, a surge protection device shall be installed at the floor/building distributor ends only. No surge protection is required at the device end. The appropriate standards, including AS 4262 and IEC 61643-21 amongst others, shall be met regarding surge protection devices.

One SPD circuit shall be allocated for each external 4 pair twisted pair cable.

The SPD devices typically come in the arrangement of a single port inline device and in 8,12,24,48 port 1-3RU panels. Single inline devices may be used for up to 4 installations per cabinet and shall be installed so they are easily accessible, but reduce interference with future cabinet installations.

If there are more than 4 required per cabinet, then the larger panel type installation shall be used. All shall be installed as per manufactures instructions.

#### 4.12 Labelling

See section 11. Labelling.

#### 4.13 Testing

See section [12. Testing](#).

## 5. Optical fibre cabling specifications

### 5.1 General

The optical fibre component of the cabling work requires the establishment of an optical fibre backbone and patching network.

In particular, optical fibre work involves, but is not limited to;

- provision of OS2 9/125 single-mode cable;
- termination of all optical fibres;
- provision of all connectors, breakout, enclosures, organizer trays, patch panels and connector couplers;
- provision of optical fibre patch cords;
- labelling of all patch panels and other equipment and;

- comprehensive testing of all optical fibres.

Optical fibres shall comply and meet the requirements of all national standards and guidelines where not defined below. Optical fibres;

- shall have a non-metallic central strength member for loose tube construction;
- shall have individually buffered fibres surrounded by strengthening components, e.g. aramid yarn, for internal riser use;
- where loose tube construction is used for internal building cabling, it shall have low smoke zero halogen construction;
- shall be of a graded index type and;
- shall conform to the national manufacturing standard.

A minimum of one 12 core OS2 fibre cables shall be installed at each location with the provision of a minimum of 100% spare capacity of the total number of utilised cores (e.g. if 4 cores shall be utilised and 8 remain unutilised, the spare capacity provision has been met). Any expansion of these fibre cables shall be installed in multiples of 12 cores. Non-terminated “future capacity” cables shall **NOT** be permitted unless explicitly exempted by the SNSDA.

In Greenfield sites, where both copper and fibre cabling is being installed at the same time (i.e. during a new school build), it is recommended that these be from the same cabling manufacturer. This allows for a single certified cabling solution throughout the site.

All installed cables on DoE sites shall be terminated at each end and associated documentation, labelling and test results shall be provided.

## 5.2 Optical Fibre Performance

Optic fibre works shall comply with all standards of the Australian Communications Authority and the Standards Association of Australia. Specifically, with the mandatory provisions of all applicable Australian Standards, and AS/CA S008 and AS/CA S009 current versions.

Where minimum specifications differ between Australian Standards AS/NZS 11801 and AS/NZS 3084:2017 then the greater requirements of Australian Standards shall apply. If a conflict of information arises consult the SNSDA for determination.

All installations shall be in accordance with the optical fibre manufacturer's specifications, including pulling tensions, support fixing distances and bend radius supports.

## 5.3 Optical Fibre Cabling Construction for Pathways

There are three (3) classifications of Fibre optical cabling to be used, based on the installation pathways of the Fibre Optic cabling; Underground, Outdoor and Indoor.

### 5.3.1 Underground:

Optical fibre cables installed with any portion of its cable in underground conduits **shall** be classified as external or outdoor grade and be equipped with loose tubes with a moisture barrier, and a nylon jacketed polyethylene sheath.

### 5.3.2 Outdoor:

Optical fibre cables that are installed in protected above ground outdoor and adverse internal pathway such as;

- roof and external wall cavities

- sub floor spaces
- conduits in environmentally protected spaces

**shall** contain a moisture barrier or blocking compound and be classified as external or indoor/outdoor grade and be low smoke zero halogen.

### 5.3.3 Indoor:

Optical fibre cables that are installed wholly within internal building spaces such as;

- Riser cupboards
- Internal ceiling cavities
- Internal wall cavities

**shall** be classified as indoor, indoor/outdoor or plenum grade and be low smoke zero halogen.

## 5.4 Optical Fibre Installation

Optical fibre installation shall be performed by an installer properly trained and qualified in carrying out the required works. All installations shall be to a high standard and in accordance with the fibre manufacturer's specification.

All optical fibre cable shall be fixed at intervals of no more than 300 mm onto cable trays with Velcro cable ties or in conduit.

All optical fibre cable shall be installed so that the cable does not exceed their manufacturer's minimum bend radius or installation tensions.

Any coiled excess shall be fully protected from physical damage and supported in such a way that the specified bending radius can be sustained for the life of the cable.

## 5.5 Optical Fibre Cabinet Pathways

All optical fibre cabling installations shall enter the cabinets from the suspended cable trays above via designated entry points on the cabinet roof corner. No cabling shall enter through the floor, front, rear or side panels. Variations shall require approval from the SNSDA.

A service loop of minimum 3m shall be maintained for each cable installed. The service loop shall be fully protected from physical damage and supported in a way such that the specified bending radius can be sustained for the life of the optical fibre cable.

The service loop or excess cabling shall be stored in the cable tray or cabinet in a neat manageable manner.

## 5.6 Optical Fibre Terminations

The termination method of all optical fibre cable shall be fusion splicing **only**.

Direct termination or mechanical jointing fibre and connectors of any type **shall not** be permitted (Excluding temporary emergency repairs).

All connectors shall be of type LC and shall be;

- single fibre 1.25 mm zirconia ceramic ferrule;
- secure, anti-snag latching mechanism;
- polarized connector to ensure proper insertion;
- be manufactured under ISO 9001 and 9002 guidelines.

Colour coding of fibre terminations in FOBOTS shall be allocated as per AS/NZS 11801:

Current Version.

Single-mode (OS1/OS2) Couplers/Duplex Adapters for fibre terminations in FOBOT shall be identifiable by the colour “BLUE”.

See Examples in Appendix D: Fibre examples for current fibre installations.

## 5.7 Optical Fibre Patch Panels (FOBOTS)

Optical fibre shall be terminated onto an approved FOBOT. Each patch panel shall be provided with patch cord support offering full protection of patch leads and connectors. Patch panels shall be in the designated equipment rack in the locations specified in the Rack layout diagrams in [Appendix B. Rack layout](#).

- Connectors shall be aligned with the mounting rails.
- Fibre terminations to the same building/floor distributor shall be grouped together in the same enclosure and not installed across different enclosures.
- Existing fibre enclosures with blank panels or slots shall be utilised before new enclosures are installed, provided that the enclosure meets current specifications and capacity requirements.
- The fibre entry to the patch panels shall be through a correctly sized and compression cable gland to prevent any movement of the fibre internal to the panel from occurring should the panel be moved.

Patch panels shall incorporate the following features:

- Allow for the termination of at least 36 LC connectors using the designated connectors while occupying no more than 1 rack units (RU).
- New enclosures being installed in an MCR (Main Communications Room/CD) shall be of a high-density model, capable of supporting a minimum of 48 LC connectors per 1RU. (See sample in Appendix D: Fibre examples).
- Be installed such that the front doors of the equipment rack shall be fully closed and lockable without any interference of equipment, cabling or patch cords within the enclosure whilst complying with specified bend radii.
- Have either a slide or swing tray to improve access (only required for Greenfield sites).
- Shall be rodent proof. Spare connector ports/panels shall be fitted with blanking panels or inserts to ensure the entire enclosure is sealed and is not accessible by contaminants or vermin.
- Grommets/compression cable glands shall be provided for all cables entering and exiting the enclosure.
- A cable strain relief bracket.
- Internal cable management rings and securing devices.
- Hinged and stacked splice trays.
- Cable entry points from the rear, top, and bottom.
- Patch panels shall utilise the designated connector couplings mounted on a pre-punched blank plate.

## 5.8 Optical Fibre Leads/Patch Cords

The contractor shall be responsible for the supply and installation of optical patch leads.

The number, length, and type of optical patch leads shall be specified by the ITD

representative, as well as any legacy fibre patch leads configurations that may be required.

A guide to current Fibre patch leads can be found in Appendix D: Fibre examples.

## 5.9 Optical Fibre Labelling

See section 11. Labelling.

## 5.10 Optical Fibre Testing

See section [12. Testing](#).

# 6. Distributor design

The size, location, and provisioning of services and facilities shall be in accordance with AS/NZS 3084 in conjunction with this document. Site distributor design includes three of the four tiers, these being:

- Campus Distributor (CD)
- Building Distributor (BD)
- Floor Distributor (FD)
- Consolidation Points (CP)

The NSW Department of Education does not support the installation of consolidation points in its network design. Any requests for Consolidation Points can only be approved by the SNSDA. Provisioning Principles include:

- Only one CD per campus
- Minimum of one BD per building
- Only one BD between FD and a CD
- Multi-level buildings shall require, at minimum one (1) BD/FD per floor.

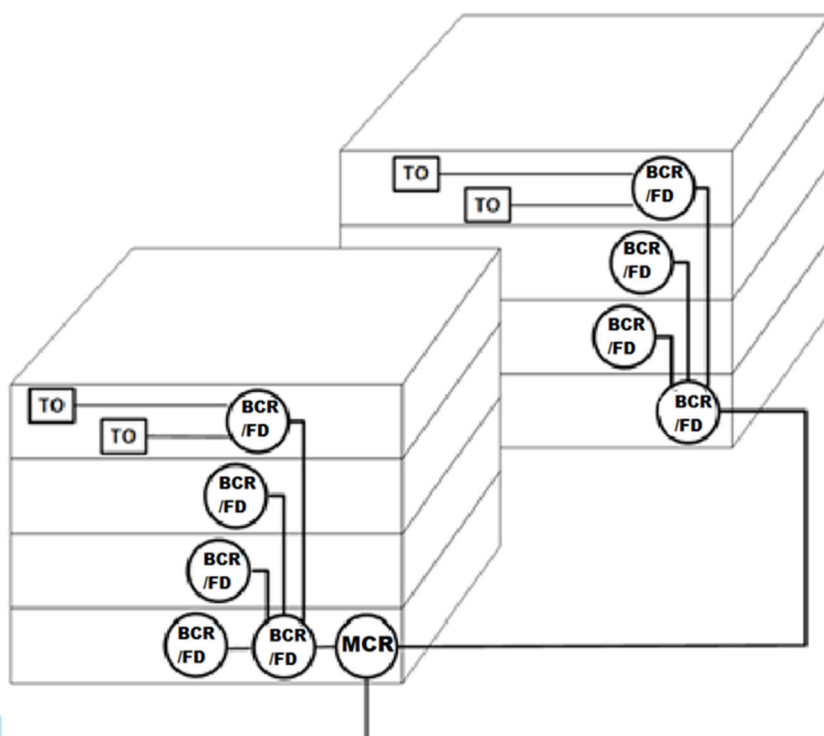

Figure 3 - Distributor design diagram

## 6.1 Communications rooms – definitions

### 6.1.1 Main Communications Room (MCR contains CD and BD)

(See AS/NZS 3084:2017 – Section 4: Equipment Room).

The CD is located in the Main Communications Room housing WAN link, servers, security, telephony, main communications, and network equipment in a restricted, secure, air-conditioned environment. This room shall also contain a BD to support any horizontal cabling terminated to this location.

### 6.1.2 Building Communications Room (BCR contains BD/FD)

(AS/NZS 3084:2017 – Section 3: Telecommunications Room).

BD/FD installations, in any buildings, shall be located in dedicated Building Communications rooms. These shall be restricted, secure, ventilation controlled environments containing network, security and telephony equipment that service a designated area of a building. In Greenfield sites, closets/cupboards of any kind is **NOT** an acceptable location for a BCR.

## 6.2 Communication Rooms – Design Principles

- All CD/BD/FDs shall be installed only in dedicated, purpose designed rooms.
- Cabinets, with side panels intact, shall be located centrally in the room.
- Cable pathways into cabinets shall be through cabinet top entry points via ceiling mounted cable trays from side walls or lowest internal facing lowest internal facing ceiling surface within the room, installed above 2300mm, to provide full access to all sides of the cabinet row.
- Cabling and services shall connect to communications cabinets above 2300mm from the finished floor level to allow for 360-degree access. The minimum dimensions of the Communications rooms shall be internal and free of columns, ducts or other intrusions into the space. The communications riser, and other services risers or equipment shall be outside the required minimum cabinet clearances.
- Inter-cabinet pathways shall be through cabinet top entry points.
- Where the project determines that fire rating is required, then approved fire-retardant materials shall be used where sealing is deemed necessary, and all fire stopping shall comply with the National Construction Code (NCC). NOTE: Sealing and fire stopping shall not impede access to cabling pathways, see 7.1.2.1 Installation. All sealed penetrations are to utilise an easily removable solution that allows for future expansion and meets the necessary regulations. i.e fire pillows/collars.
- Communications rooms shall house only communications, network, security, telephony, building monitoring systems and IT related equipment. Access to communications rooms shall be restricted to authorised technicians and school staff.
- Only split system air conditioning units shall be installed in Communication rooms. Cassette type air conditioning units are not permitted to be installed, and air conditioning fan coil units that service the building are not permitted to be installed in Communication rooms. The ceiling space above the racks shall be clear of any services to allow for the suspension of cable trays and pendant power.

- Communications rooms shall not be used to store any un-used equipment or items. Using communications rooms as a storage space represents an OH&S hazard to technicians and school staff requiring access to the equipment housed within. No other services (e.g. electrical risers/boards/cupboards, water, mechanical) shall travel above, through or be installed in these rooms.
- All communications rooms shall have anti-static vinyl floor covering. Sealed, concrete floors are also acceptable.
- In the MCR/CD room a 4 step fibreglass ladder, with a minimum 120kg load rating is required.
- A telephone is required per MCR.
- A KVM with a fold out monitor must be used for any non-DoE managed services located within racks.
- All main communications rooms shall have capacity for an additional cabinet (with power sockets pre-provisioned) marked as “Future Expansion” in the room specifications. This is not to be utilised during installation and if additional cabinet capacity is required, then the room shall be expanded to accommodate the additional cabinets while retaining expansion capacity.

## 6.3 Communication Rooms – Locations

### 6.3.1 Main Communications room (MCR contains CD and BD)

The Main communications room shall be located in the school Administration building. If this building is not centrally located on the site, the MCR may, with SNSDA approval, be installed in the Library or other building in a central and secure location, as long as all the minimum room requirements are met.

All site communication services such as WAN links, servers, security, telephony, main communications and network equipment shall be located in the main communications room. Under no circumstances shall these services be installed in separate locations.

### 6.3.2 Building Communications Rooms (BCR contains BD/FD)

For a building that contains two (2) or more BCRs, one shall be defined by the SNSDA as the primary BCR (containing Building Distributor) that is connected to the Campus Backbone cabling and will service other BCRs (containing Floor Distributors) located in the same structure using the buildings backbone cabling.

### 6.3.4 Single level buildings:

Building communications rooms shall be located centrally to reduce cable pathways and assist with future expansion. In high outlet density areas or larger buildings, it shall be required to install further building communications rooms to reduce cable congestion and/or meet security/horizontal cabling requirements.

### 6.3.5 Multi-level buildings:

Multi-level buildings shall require, at minimum, one (1) building communications room per floor. These shall be located centrally to service the largest floor area and close to the inter-floor cable risers.

In high outlet density areas or larger buildings, it shall be required to install further building communications rooms per floor to reduce cable congestion and/or meet security/horizontal cabling requirements.

The DoE SNSDA team may approve a building communications room to service an adjacent floor that is not heavily populated and if all the requirements for security/horizontal cabling can be met. This shall be at the SNSDA's discretion.

See Appendix A. Room distributors for MCR and BCR layout designs.

### 6.3.6 Multiple structures under one roof line

Where multiple structures (buildings) exist under one common roof line, then a communication room is required per structure and shall abide by the design principles as set out in this document. Under no circumstances shall horizontal cabling from one structure be terminated into a communication room in a different or adjacent structure, either through the common roof line, covered walkway or other. From a structured cabling perspective, each structure is considered a separate independent building and thus requires cabling for that structure to be serviced by the same structure.

### 6.4 Cabinet specifications

The table below shows the required cabinet specifications:

Item	Specification		Additional Information
	Main Communications Room	Building Communications Room	
Height	45RU		
Depth	1000mm	800mm	
Width	800mm		
Maximum External Height	Less than 2250mm		
Construction Type	All Metal construction.		
Doors, front & back	Metal construction, reversible and removable. Perforated front and rear metal doors with a minimum of 60% open surface for ventilation. Key lockable and latched. The rear door shall be split door arrangement (French Doors)		No Glass or Perspex
Side Panels	Metal construction. Solid metal removable panels. External key lockable		
Front Rails	Standard 19 inch as IEC 60297-2 or later		Adjustable through the full depth of the cabinet. Set back minimum 150 mm from front door "L" Shape profile
Rear Rails	Standard 19 inch as IEC 60297-2 or later		Adjustable through the full depth of the cabinet. "L" Shape profile Depth shall be set after installation.
Shelves	Full depth, Metal perforated		Minimum 1 per cabinet
RU markings	On both front and rear rails		
Security	Doors & sides external key lockable		L & F 92380 key code. Three (3) point locking handle
Mounting	Floor mounted with adjustable feet.		Floor mounts shall be squarely located using adjustable feet to the floor. Castor wheels are <b>NOT</b> to be used to support the weight of the cabinet.

Item	Specification		Additional Information
	Main Communications Room	Building Communications Room	
Vertical cable management	2 per cabinet located outside of each front rail. Running full height of the cabinet. D-ring cable manager. Side slots are to be of solid type.		Large open slotted duct that allows the ability of many cables to be in one duct at any one time. Tightly compressed ducts are not permitted. Minimum depth of 100mm. 25% spare capacity once all patch leads have been installed.
2RU Horizontal Cable Managers	1 Per cabinet, installed at the top of the front rail of the cabinet		D-ring cable manager. To be fitted with Cat6A bend radius compliant guides spaced at one rack unit or similar. Minimum depth of 100mm. Must be of sturdy construction material and supplied by either the rack manufacturer or cabling manufacturer.
1 RU Horizontal Cable Managers	1RU cable manager per 2RU of distributor panels		D-ring cable manager. Minimum depth of 100mm. Must be of sturdy construction material and supplied by either the rack manufacturer or cabling manufacturer.
External power	2 per cabinet. Dedicated 20A circuit per outlet, including Future Expansion cabinet		15A screw captive pendant socket outlet. RCD and surge protected. Not to be installed in or on the cabinet. Please note that the server UPS in Cabinet 1 (MCR) might need a longer power lead to reach the captive socket. If a longer power lead cannot be sourced then lowering the 15A captive socket is permitted pending SNSDA approval.
Earthing	All racks shall be bonded to Protective Earth		
Top Panel ventilation	1 per cabinet for non-air-conditioned rooms. Dual fans fitted internal to cabinet ceiling.		Not required for air-conditioned rooms.
Power Distribution Units	1 per cabinet. 10 way vertical. 15A captive plug. Mounted at cabinet rear, right side.		Connected to 15A locking captive pendant socket outlet above the cabinet, supported by a chain. 12 way vertical PDU may be required in MCR racks.

Cabinet Layouts can be found in Appendix B. Rack layout.

For existing MCR cabinets, 4RU of contiguous space must be reserved at all times to allow for moves, adds and changes (MAC). For existing BCR cabinets, 2RU of contiguous space must be reserved at all times to allow for MAC. Where existing cabinets have no reserved space then a suitable sized cabinet shall be sourced and installed, contact the DoE SNSDA team for advice and endorsement.

### 6.4.1 Outdoor Cabinets

In outdoor areas, where a requirement to connect services such as external WAPs and security devices (CCTV cameras, Gate controllers, Intercoms etc.) exists; where no MCR / BCR is within cable distance limits; an outdoor minimum 24RU, IP54 rated 600mm deep cabinet shall be installed. The cabinet shall be securely mounted, and weather sealed to an appropriate concrete plinth. Conduit paths shall penetrate through the concrete plinth at the cabinet base. Outdoor cabinet locations shall not introduce a climbing point.

A Dedicated 15A circuit connected to a 15A Captive socket, RDC and surge protected outlet shall be provided 300mm above from the concrete plinth within the cabinet. Cabinet shall include an earthing bar as per section 8 of the SCSS. The cabinet shall have a horizontally mounted six-way power distribution unit mounted at the top of the cabinet. External cabinet walls shall not be penetrated.

The network switch installed in the cabinet shall be capable of handling the environmental conditions and thus be IP rated or of an industrial type. Locations requiring outdoor cabinets shall be marked on electrical drawings, with detail showing how the outdoor cabinet will be connected via the campus backbone pathway. Exceptions including adding additional equipment to existing outdoor cabinets shall be directed via SNSDA as per section 2 of the SCSS.

## 6.5 Cabinet Layouts

### 6.5.1 Cable pathways:

- Cable pathways consist of two components, Cable trays and Optical Fibre Trunking (Raceway).
- Cable pathways to cabinets shall be via suspended cable trays, to be installed at a minimum of 2300mm FFL, above the cabinet. The distance between the top of the cabinet and the bottom of the raceway shall be between a minimum of 100mm and a maximum of 300mm.
- Cabling of any type shall not be run across floors or at a height less than 2300mm to cable trays.
- Cable trays and Optical Fibre Trunking (Raceway) may be installed on the same suspension framework and shall extend the full length above the cabinet installation row including the future expansion area.

### 6.5.2 Cable trays:

- Are for data communications including fixed fibre and security cabling only. Cable trays shall not be used for power installation.
- Shall be either pre-galvanized, hot dipped galvanised, stainless steel or of powder coated material. Zinc plated steel cable trays are not to be used.
- Fibre and copper types of fixed communications cabling shall be secured separately in cable trays and separated from inter-cabinet cabling (which may be added or removed).
- Pathways to cable trays shall be run vertically on external walls and then horizontally across to the cable trays.
- **SHALL NOT** be attached to cabinets but suspended from ceiling, walls or installed support beams.
- Shall allow for 50% capacity when installed to allow for future expansion.
- Shall not to be used for inter-cabinet fibre or copper patch leads.
- Entry and exit points shall have approved bend radius support for the installed cabling.

### 6.5.3 Optical Fibre Trunking (raceway):

- For optical fibre and copper patch leads between cabinets, not fixed fibre or fixed copper.
- To be installed towards the front side of cabinets.

- Contains two drops into each cabinet, front left and front right through the cabinet ceiling.
- Shall be of a manufactured construction type designed for the purpose of fibre run installations with appropriate bend radius and supports installed.
- Shall allow for 50% capacity when installed to allow for future expansion.
- Shall **NOT** be attached to cabinets but suspended from ceiling, wall or installed support beams and to be the same supports used for the cable tray system.

## 7. Pathways

### 7.1 General

The implementation of appropriate pathways within DoE campuses is essential for longevity and serviceability of the cable plants. The pathways used in DoE are categorized in to three systems, Campus Backbone, Building Backbone and Horizontal.

Campus Backbone pathways are those that provide support and security of cabling between buildings.

Building pathways are those that provide support and security of cabling within buildings between distributors.

Horizontal pathways provides support for cabling between the distributor and the work area. The choice of materials used in the pathway should consider environmental factors such as highly corrosive environments, e.g. hot dipped galvanized steel cable trays in locations close to salt water.

Separation between power and telecommunications cables, including earthing cables, shall be as detailed in AS/NZS 11801.1:2019 and AS/CA S009:2020. The separation shall be maintained at all times, at entry or exit points, crossovers, junctions and all accessories and fittings.

All pathways shall comply with the latest versions of AS/NZS 11801.1, AS/CA S009 and AS/NZS 3084.

#### 7.1.1 Campus Backbone Pathways

All campus backbone pathways and cabling shall be Optical Fibre cabling, as specified in section 5. Optical fibre cabling specifications, and installed as an underground conduit and pit system. Above ground conduit, direct buried and/or aerial catenaries are prohibited for campus backbone cabling.

The campus backbone pathway connects the MCR to the buildings primary BCR that contains the building distributor. The primary BCR shall be nominated by the SNSDA and shall then service other BCRs in the same building using building backbone cabling.

Due to the varying school designs and works at brownfield sites, the SNSDA may require individual BCRs to be cabled directly back to the MCR and shall advise during the design phase if this is required. Carrier lead-in cabling, consisting of a pit and conduit (4 x 50mm) system that is installed between the MCR and the boundary of the property is for carrier use only and is not to have any DoE or other agency cable installed. Communication and co-ordination is required between the carrier, the builder and departmental staff to ensure that the lead-in cabling is installed within an adequate time-frame.

Low capacity buildings with less than 10 TOs (5 DTOs) with no possibility of future expansion, may not require a Campus Backbone pathway and TOs can be cabled back to nearest BCR using underground external grade horizontal cabling installed in

underground conduits and pits. This is at the SNSDA's discretion and should be identified at the design stage.

#### 7.1.1.1 Installation

Campus backbone pathways shall be installed completely underground to fixed buildings only. No part or any portion of the pathway shall be installed on awnings, verandas, walkways or any structure that is not part of the main building. The underground pathways shall begin underneath the building where possible or enter the ground directly at the building's footprint edge.

#### 7.1.1.2 Underground Conduit and Pit

The minimum underground conduit pathway consists of two (2) X 100mm conduits between pits (also between building entry pits and the MCR, or primary BCR location). Existing buildings may use (4) X 50mm from the building entry pit to the MCR or primary BCR if pathway cannot support (2) X 100mm. The request to use 50mm conduits, in lieu of 100mm conduits, must be raised via the SNSDA before any works commence. See Appendix G: Conduit and pit diagrams.

For installations where only an optical fibre cable is installed in an underground conduit, a 4 square millimetre copper wire is also to be installed as a locator/trace wire. The locator cable is not to be coloured red, black, blue, purple or white.

All conduits shall be installed with the appropriate draw cord. White marking tape shall be installed at least 100mm above the conduit. The ends of conduits shall be sealed at the building entry point and within the pit. Drainage holes and drains shall be provided in all pits. The pits shall be positioned such that conduits do not drain into buildings.

The conduit numbers and pits shall be sized appropriately for the number of cables in a conduit with expansion capacity. Conduits shall be considered as "full" when the cross-sectional area of the planned/installed cables reaches 40% of the conduit cross-sectional area.

Conduit fill factor comprising **[the sum of cable cross-sectional areas] / [conduit inner cross-sectional area]** shall not exceed the requirements of AS/NZS ISO/IEC 14763.2 for straight conduit runs. For new installations, this should be 24% (comprising 40% ultimate fill less 40% of this as spare capacity).

The location of the building entry pit shall be as close as is practical to the room housing the primary BCR or MCR.

Pits used in roadways and traffic areas may require a higher rated lid and hence the appropriate weight carrying capacity lid shall be used. Pit lids shall be labelled as "Communications" or "Comms".

Additionally:

- Pits used as the building entry to the MCR shall be a minimum size of Pit Type P8.
- Pits used to extend the main campus pathway shall be a minimum size of Pit Type P6.
- Pits used for building entry shall be a minimum size of Pit Type P5.
- The use of existing carrier conduits and pits for DoE cabling is **strictly prohibited**.
- DoE telecommunication pits and conduits shall only be used for DoE telecommunication cabling, no other services are permitted to use telecommunication pits and conduits.

- Only the 2 x 100mm conduits, 2 x 50mm security conduits and carrier only conduits shall enter the MCR unless approved otherwise by the SNSDA. Conduit fill factor, as detailed in section 7.1.1.2, must be adhered to.
- The maximum distance between the vertical cable tray that the conduits will be placed against, and the wall when the conduits enter the MCR must not exceed 50mm. The conduit/vertical cable tray must be protected by a metal cover lid (min 1.6mm gauge) to 2 metres high. See diagram in Appendix G.

All conduits and pits shall be documented with the following details to be included:

- conduit pathways
- depths of all conduits and pits
- pit sizes and locations including GPS coordinates
- See 13. Documentation for detailed information.

## 7.1.2 Building Backbone Pathways

If a building contains more than one BCR, a primary BCR (containing the building distributor) shall be nominated by the SNSDA to connect to the campus backbone cabling. This BCR may then service other BCRs located in the same building using building backbone pathways.

Each BCR in a building shall be connected on its own cabling back to the primary BCR.

All building backbone pathways and cabling shall be Optical Fibre cabling, as specified in section 5. Optical fibre cabling specifications.

### 7.1.2.1 Installation

All pathways shall have a minimum 50% spare capacity at the time of installation.

Vertical pathways between floors shall be a minimum of (2) X 100mm conduit sleeves or slots.

Building backbone pathways shall be accessible throughout their length. The pathways shall use the cable lay-in method for installation of cabling.

Building backbone pathways shall be a fully enclosed system consisting of metal trays or trunking with lids/covers or a combination of both and may use horizontal cabling trays or trunking as long as spare capacity is maintained.

Metal pathways shall be bonded to protective earth. Conduits are acceptable for installation in concealed spaces only.

### 7.1.2.2 Fibre capacity

Minimum installation is 12 core of single-mode fibre for all building backbone cabling. The SNSDA shall advise during the design phase if an increase is required.

## 7.1.3 Horizontal Cabling Pathways

Horizontal pathways connect the BCRs to work area Telecommunications outlets.

All horizontal pathways and cabling shall be Cat6A, as specified in section 4. Horizontal cabling specifications.

### 7.1.3.1 Installation

The primary method for installing horizontal cabling shall be metal trays or trunking that shall be installed throughout the building to reach all cabled areas.

This shall be incorporated into the building planning at the design phase to allow capacity for these pathways and access to them for future expansion works.

Building distribution pathways shall be accessible throughout their length, with access/service hatches strategically placed ensuring accessibility. Pathways shall use the cable lay-in method for installation of cabling.

Where retrofitting existing buildings, proposed pathways shall need to be approved by the DoE ITD Representative.

Horizontal cabling pathways shall be a fully enclosed system consisting of metal trays or trunking with lids/covers or a combination of both.

- The minimum width of the tray or trunking is 75mm
- The minimum depth of the tray or trunking sides is 50mm

Metal pathways shall be bonded to protective earth. Conduits are acceptable for installation in concealed spaces only. Conduits entering the underneath of buildings shall extend to the underfloor surface and be affixed to the floor structures. Cable runs that contain ten (10) or more cables shall use either a tray or trunking, for runs of less than ten (10) cables, the catenary wire may be used. Cable runs shall not be separated into groups of ten (10) or fewer cables to avoid installing cable trays or trunking.

The size of the pathway shall be increased if the cabling to be installed exceeds the maximum fill space. The pathway shall allow for 100% expansion of cable carry capability based on the number of cables being installed at the time the pathway is installed. If the number of cables to be installed plus the 100% expansion exceeds the minimum dimensions (75mm x 50mm) then the pathway shall be increased in size accordingly.

In all cases where the pathway is exposed, the cabling shall be fully enclosed in a metal material that is securely fixed with removable screws throughout its entire length. This applies to pathways used for vertical and horizontal reticulation of cables. An exposed pathway is defined as being visible and accessible to the general pedestrian. This is regardless of the level of supervision present at any time. The exposed pathway shall be aesthetically matched to the surrounds of the room.

Where appropriate, multi-channel PVC ducts can be used for the reticulation of cables to the final outlet location. There need to be a minimum of two (2) channels, one for telecommunication cables, and another for power cables. No excess cables shall be stored in the ducts and all ducting shall be securely fixed to the surface using the appropriate method. The duct shall be clear of any burrs and other sharp spikes or edges.

Cables installed in cavities (wall partitions, columns, etc.) shall meet the mandatory separation from power cables as specified in AS/NZ 11801: Current Version. The area shall also be free from sharp edges, ensuring no strain is placed on the cable.

Appendix C. Pathway materials and fixings contains a list of acceptable products and materials/fixings used in pathways.

In summary, the following table lists what is acceptable and what is not:

<b>Campus Backbone Pathways</b>	Underground conduit (and pit system) is required for campus backbone pathways.
	Above ground conduits of any size are not to be used for Campus backbone cabling.
	Conduit is an acceptable pathway to demountables.
	Existing carrier conduits and pits are not to be used for DoE cabling.
<b>Building Backbone Pathways</b>	Transition from Campus to Building Pathway - Conduits entering the underneath of buildings shall extend to the underfloor surface and be affixed to the floor structures. Shall consist of Fibre Optic cabling only, unless exemption for any other type of cabling (i.e. Copper) has been approved by the SNSDA.
	Building Backbone pathways shall be a fully enclosed system consisting of metal trays or trunking with screw fixed lids/covers or a combination of both
	Vertical pathways between floors shall be a minimum of (2) X 100mm conduit sleeves or slots.
<b>Horizontal Cabling Pathways</b>	The cable pathways in accessible ceiling spaces may use an open pathway.
	A tray/trunking system shall be used for 10 or more cables or a catenary wire system may be used for a smaller number of cables.
	The penetration into the building shall be fully enclosed using a conduit or suitable material.
<b>Local Distribution Pathways (from the horizontal cabling pathway to the final outlet destination)</b>	Communications conduits are acceptable for installation in concealed spaces only.
	Wall cavities may also be used.
	Where the pathway shall be surface mounted PVC trunking shall be used.

## 8. Earthing

Every communication room (MCR, BCR) shall be provided with a Communications Earth System (CES), used for both functional earthing and protective earthing purposes. Earthing conductors used for a CES system shall have green/yellow insulation. The size of the earthing conductor shall be in accordance with AS/CA 2009 and be installed in accordance with industry best practices.

Any electrically conductive support system for cables shall be earthed. This includes but not limited to metallic cable trays, trunking systems, distribution frames, mounts, enclosures, racks, cabinets, or catenary supports. A Communication Earth Terminal (CET) shall be installed in each communication room (MCR, BCR). A CET is the terminal that the earthing system connects to within the communications room.

Where shielded cables are installed, the contractor shall ensure that shield earthing complies with AS/CA S009 and AS 30129: Current Version plus the manufacturer's advice. Each patch panel for the shielded outlets and shielded cables shall be individually earthed to a single earth point on the cabinet/rack or to an earth bar within a cabinet.

As part of the handover documentation, the contractor shall provide communications drawings showing the earthing system, in particular the CET.

## 9. Demountables

Where demountable buildings are being installed, it is imperative that DoE ICT representatives be involved from the initial planning phase. As a general rule if one demountable is required then depending on the distance between the demountable and the nearest BD, horizontal cabling (typically external grade) can be used (with surge protection if required).

However, when a cluster of demountables is being installed or upgraded, a fibre backbone shall be installed to the nearest located BD to the demountable. Other demountables in that cluster shall then cable back to that distributor. The fibre installation shall adhere to the specifications set out in this document.

The use of Aerial catenaries is strictly forbidden.

Distributor cabinet sizing shall take into consideration the number of existing and future demountables.

## 10. Capital works/refurbishment/expansions

For existing sites, where capital works, refurbishments and/or expansion are taking place, these works shall comply with the standards as set out in this document. DoE ITD representatives need to be involved in the lifecycle of the project (from pre-planning, implementation and sign off) to ensure that all works are being correctly specified and these specifications are adhered to.

It is recognised that the installation of the new cable plants will be disruptive to users. Wherever possible, the existing cabling shall be retained in a working state until an orderly cut-over is arranged with the school.

All cabling no longer fit for purpose, redundant or abandoned shall be removed and disposed of, and any penetrations suitably sealed and made good.

New fibre installation, regardless of the number of fibre cores being installed and regardless of the existing fibre type on site, the standards stated in this document (OS2,

minimum 12 core) shall be adhered to.

Any cabling infrastructure found and identified by the contractor to be non-conforming to DoE guidelines, the manufacturer's guidelines, or Australian Standards shall be reported to a DoE project manager for further investigation.

## 11. Labelling

All components of the Cabling Subsystem shall be labelled with machine generated etched labels (i.e traffolyte). These labels may be part of the vendor's product range. The labelling system shall be fixed to the component, be considered as permanent and last for the entire life of the device. Tape labels are not acceptable, with the exception of internal WAP labelling, see section 11.5.1. Handwritten labels are not acceptable on any part of the cabling subsystem. All labelling is to conform to AS 3085.1 current edition.

The font used shall be Arial, Times New Roman, Helvetica or of a similar type, that is easily readable. All text shall be in capitals as in examples below.

### 11.1 Cabinet labelling:

Text shall be a minimum of 10mm in height. The name of the distributor shall be attached to the front and top of the cabinet (External) and shall form part of the label for the outlets.

Cabinets shall be named according to their AMS room code and numbered sequentially from the left of the door entering the room:

- "AR0001-C1" is the first cabinet located in AR0001
- "AR0001-C2" is the second cabinet located in AR0001.

For the Main Communications Room, see specific cabinet numbering sequence in [Appendix B. Rack layout](#)

### 11.2 Fibre cable labelling:

Text shall be a minimum of 5mm in height.

Campus Backbone cables and termination panels shall be labelled with the number of cores, type of cable and the destination distributors AMS room number.

An example labelling of a 12 core OS2 installed from Block A, room AR0012 (MCR) to Block B, room BR0015 (BCR) is:

- On the Block A FOBOT the label shall read – "12 CORE OS2 TO BR0015"
- On the Block B FOBOT the label shall read – "12 CORE OS2 TO AR0012".

Labels shall be placed on the individual FOBOT inserts (on, above or below) where the cables are terminated and not impede any future insert installations or labelling requirements. Apart from fibre safety labelling, all other labelling on the FOBOT lid is strictly forbidden.

Every fibre cable, in every pit, shall be labelled using an outdoor grade label that is machine printed with the AMS source and destination location. That same cable shall also be labelled as it enters the room, in a location where it is visible, preferably just before it enters the FOBOT.

An example label is – "AR0012 TO BR0015".

### 11.3 Horizontal cable labelling in cabinets:

Text shall be a minimum of 5mm in height.

Distributor cables and panels shall be labelled with unique and contiguous numbers. The outlet on the panel number shall match the outlet numbers and shall traverse cabinets in the same room for larger installations. A vendor's labelling solution may be used on the copper patch panels provided that it is tamper proof, machine generated and lasts for the entire life of the device.

Example: Outlets 1-192 in the cabinet C1 and continue with 193+ in cabinet C2.

### 11.4 Telephony cable labelling in cabinets:

Text shall be a minimum of 5mm in height.

Telephony cables and panels shall be labelled with a unique and contiguous number for the UTP connected. The outlet on the panel number shall match the outlet numbers in the corresponding cabinet where the cabling is terminated. Sequential numbering such as 1, 2, 3... is sufficient.

Example labelling of a 10 pair installed from Block A, room AR0012 (MCR) to Block B, room BR0015 (BCR) is:

- On the Block A UTP backbone the label shall read – “10 pair UTP TO BR0015”
- On the Block B UTP backbone, the label shall read – “10 pair UTP TO AR0012”
- With each RJ45 outlet marked as 1, 2, 3.

The label shall be placed on the panel either above or below where the cables are terminated and not impede any future insert installations or labelling requirements.

Every UTP cable, in every pit, shall be labelled using an outdoor grade label that is machine printed with the AMS source and destination location. That same cable shall also be labelled as it enters the room, in a location where it is visible, preferably just before it enters the patch panel.

- An example label is – “AR0012 TO BR0015”

### 11.5 Telecommunications Outlet labelling:

Text shall be a minimum of 5mm in height.

Telecommunications Outlets shall be labelled with the distributor cabinet they are terminated at and a unique and contiguous number that corresponds to the number on the distributor patch panel. See section “Horizontal cable labelling in cabinets”. TOs installed below 1600mm FFL shall have the labels on the top of the wall plate, and outlets installed above 1600mm FFL shall be labelled on the bottom of the wall plate for easy identification.

See examples below:

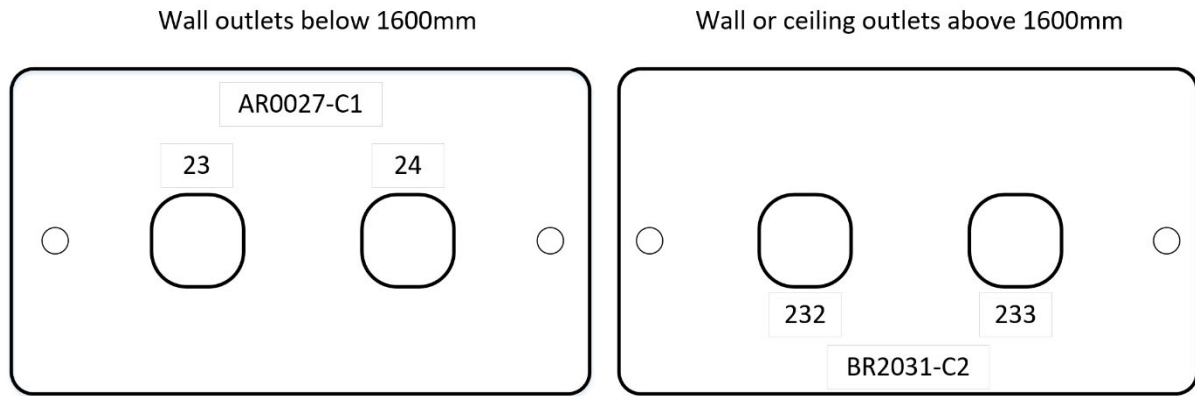

Figure 4 - Wall outlet diagram

This outlet is terminated back to room AR0027, cabinet C1 and the patch panel numbers are 23/24

This outlet is terminated back to room BR2031, cabinet C2 and the patch panel numbers are 232/233.

### 11.5.1 Access points:

For internal Access points, machine printed labels shall be affixed to the WAP with the WAP name used within WAP programming for easy identification. Minimum text height of 10mm and legible from ground level.

For external Access points, additional external grade labelling is required on the bottom of the waterproof outlet box. It shall contain the same information as the outlet wall plate label inside the box with a minimum text height of 10mm and legible from ground level. The WAP name is to be also displayed on the WAP itself. See example in Appendix E.

### CCTV Cameras

For CCTV cameras, an appropriate grade label shall be attached to the body/bracket of the device that in no way impedes the field of view of the camera. The corresponding telecommunication outlet at the patch panel end must be included in the label that will be put on the CCTV camera for identification purposes.

## 12. Testing

### 12.1 General

Prior to testing taking place, all cables and outlets shall be fully terminated and installed in their final locations and labelled accordingly (See section 8, 11. Labelling). 100% of all cables shall be tested and all testing shall be carried out in accordance with the relevant standards, namely AS/NZS IEC 61935.1 and ISO/IEC 14763-3.

### 12.2 Horizontal Cabling

Installers shall individually test 100% of all copper cables and all testing shall meet, or exceed, the manufacturer's warranty and testing requirements.

Permanent link performance is the preferred acceptance criteria for all horizontal cabling installations. Resistance Unbalance and Resistance Balance between Pairs shall be tested for PoE purposes. The Permanent link performance, and channel performance shall meet the minimum requirements of:

- AS/NZS 11801:Current Version for Class EA (using Cat6A components), or
- ISO/IEC 11801:Current Version for Class EA (using Cat6A components)

All permanent links shall be tested in accordance with AS/NZ IEC 61935.1.

All results shall be supplied (in both original and in .pdf format) to DoE representatives prior to the acceptance of the site. The documentation shall clearly identify the DoE site and the circuit/link being tested. All testing lengths shall be indicated in meters, not feet. Date stamps and the name of the company and technician shall be included. The installer shall also provide to DoE the manufacturer's warranty certificate, along with other documentation such as "as built diagrams" (see section 13. Documentation).

### 12.3 Optical Fibre

The testing of the optical fibre cable plant shall include:

- Power Insertion Loss (PIL)
- Optical Time Domain Testing
- Length and Propagation Delay

For PIL testing, a Light Source and Power Meter shall be used, Optical Time Domain Reflectometer (OTDR's) are not to be used. The optical characteristics of the optical fibre cores shall be tested using an Optical Time Domain Reflectometer. The length and propagation delay testing may form part of the PIL or OTDR testing.

All testing shall meet, or exceed, the manufacturer's warranty and testing requirements. Testing shall be conducted in accordance with AS/NZS ISO/IEC 14763.3.

Testing shall be carried out at in both directions and in the following the optical wavelengths:

- 1310nm
- 1550nm

All test results shall be included with the as-built documentation. The test results shall be presented in their native electronic format as well as PDF format.

## 13. Documentation

The contractor shall provide the following post-installation documentation as part of the contract.

### 13.1 As-Installed Drawings

The as-installed drawings shall include as a minimum:

- Plans showing cable pathways
- The cable pathways shall indicate main components – trays, pits, risers
- Backbone cabling and Horizontal cabling shall be marked separately
- Locations and labelling of outlets
- Locations of distributors

Electronic versions of drawings shall be supplied to DoE as an AutoCAD and/or Adobe PDF drawings. If using scanned hand altered copies of site maps, any as installed alterations need to be clear and legible. DoE entities usually hold hard and soft copies of plans in Adobe PDF of all buildings on their sites. Copies can be made available on request to the site cabler to mark up with the As-Installed works. If requested as part of the design, photos shall be provided by the contractor.

## 13.2 Test Results

The test results shall include those stated in the Structured Cabling System Testing Requirements as mentioned in this document.

The above documentation shall be provided in two hardcopy volumes plus one softcopy. As-Installed Drawings are preferred to be marked up Adobe PDF drawings. However other formats are acceptable. The test results, both in original and .pdf format, shall be provided in softcopy only.

## 13.3 Warranties & Certification

In instances where site cabling is being performed as part of other building work, and these works are managed by a prime contractor or builder, the standard defects and liability warranty shall apply. Warranties required under prime/builder contracts shall precede those stated below for only the term of the prime contract warranty.

### 13.3.1 Site Cabling Warranties

The contractor shall provide a warranty to make good any part of the SCS found to be faulty due to faulty manufacturer materials and/or inadequate installation practices or workmanship. The period of the warranty shall be not less than five (5) years inclusive of any other defects liability period. Pathways are considered a part of the SCS. Hence the conduits and pit systems, catenary and fasteners and duct works are all to be included within the warranty.

### 13.3.2 Manufacturers Certification

In addition to the above warranties, the contractor shall provide a manufacturers application and product certification for the SCS. The certification shall include the supply of products and labour to rectify cabling found to be faulty. The minimum period of certification shall be twenty (20) years. A certification which also warrants the cable pathway and its components are preferred.

The manufacturer's certificate shall be provided in hard copy and electronic format. A scanned image is acceptable. Certifications which do not have as part of the manufacturer's program an installers training program are not acceptable. The manufacturer's installer training program shall include a design and installation component. The installation training shall include the testing of fibre and copper installations required to perform tests required of this specification.

### 13.3.3 Multiple Vendor Certifications

In brownfield sites, it is acceptable for multiple vendors to provide certifications for either the twisted pair and/or optical fibre cable plants. However, the combined cable plants shall be included and the vendors shall comply with the certification training requirements above. The contractor shall not void any manufacturer's certifications or warranties on previously installed structured cabling systems.

## 13.4 Cabling Checklist

The Cabling checklist attached in Appendix I: Cabling Checklist, shall be used where there has been an installation of copper or fibre cabling in any NSW DoE school premises.

## Appendix A. Room distributors

### Main Communications Room

**Schedule Area**  
15.5m<sup>2</sup>

**Notes**

**1** Minimum room requirements are critical dimensions due to equipment being installed.

**2** Minimum Ceiling height is 2700mm

**3** All cable pathways into cabinets are to be via cable trays installed above 2300mm

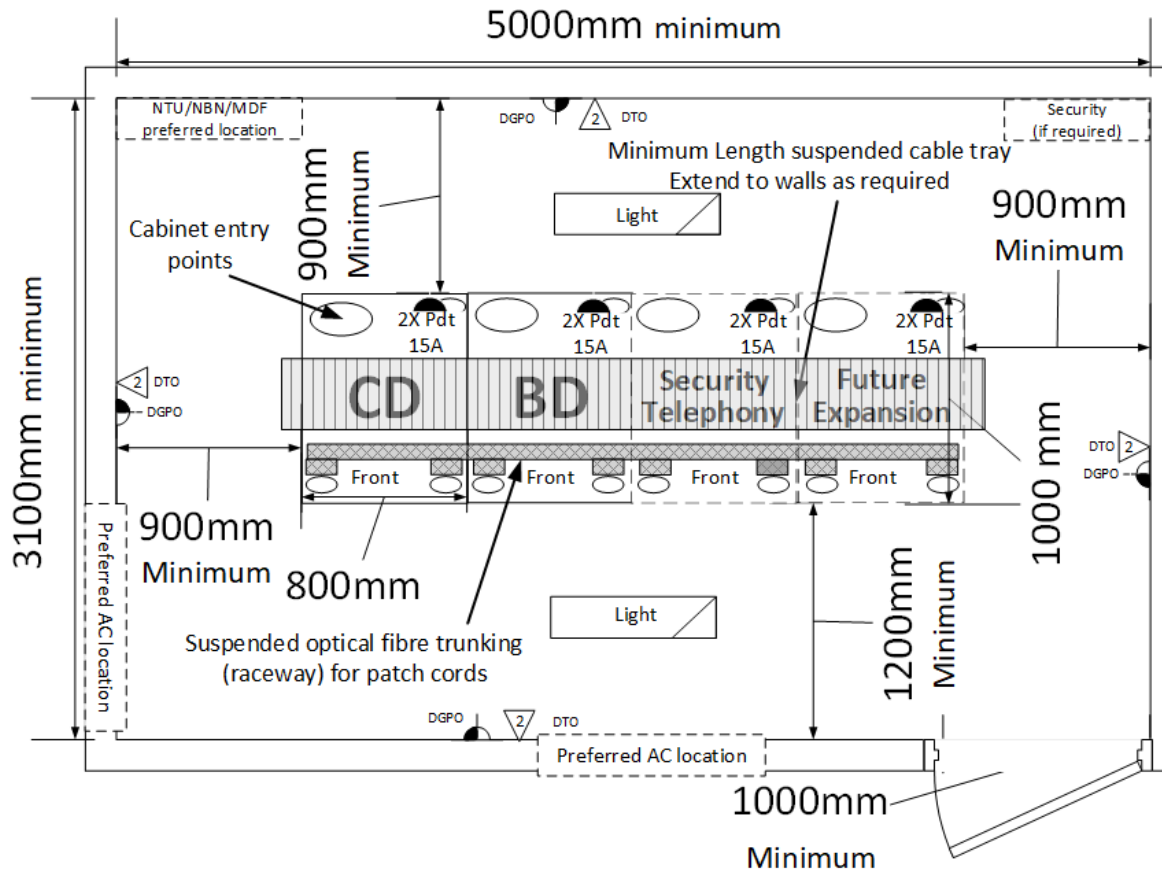

Figure 5 - Main Communications Room

## Building Communications Room (BCR)

(Single Cabinet)

**Schedule Area**  
8.4 m<sup>2</sup>

**Notes**

**1** Minimum room requirements are critical dimensions due to equipment being installed.

**2** Minimum Ceiling height is 2700mm

**3** All cable pathways into cabinets are to be via cable trays installed above 2300mm

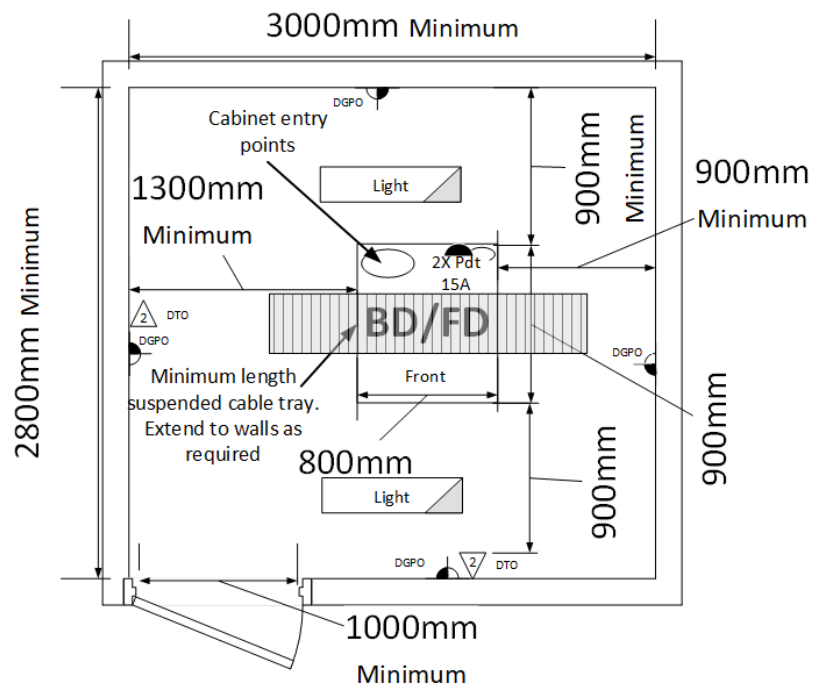

## Building Communications Room (BCR)

(Dual Cabinet)

**Schedule Area**  
8.4 m<sup>2</sup>

**Notes**

**1** Minimum room requirements are critical dimensions due to equipment being installed.

**2** Minimum Ceiling height is 2700mm

**3** All cable pathways into cabinets are to be via cable trays installed above 2300mm

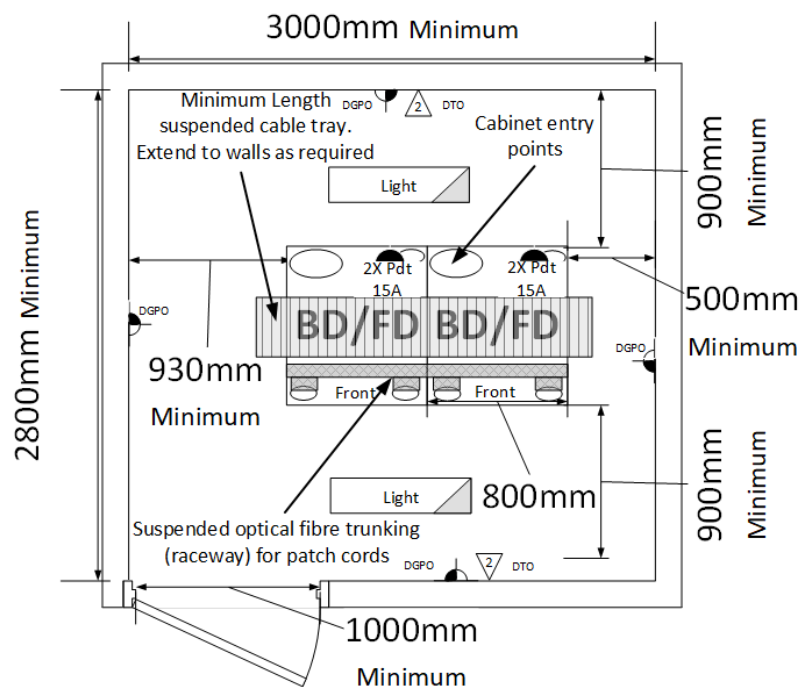

Figure 6 - Single and Dual Cabinet Building Communications Rooms

# Appendix B. Rack layout

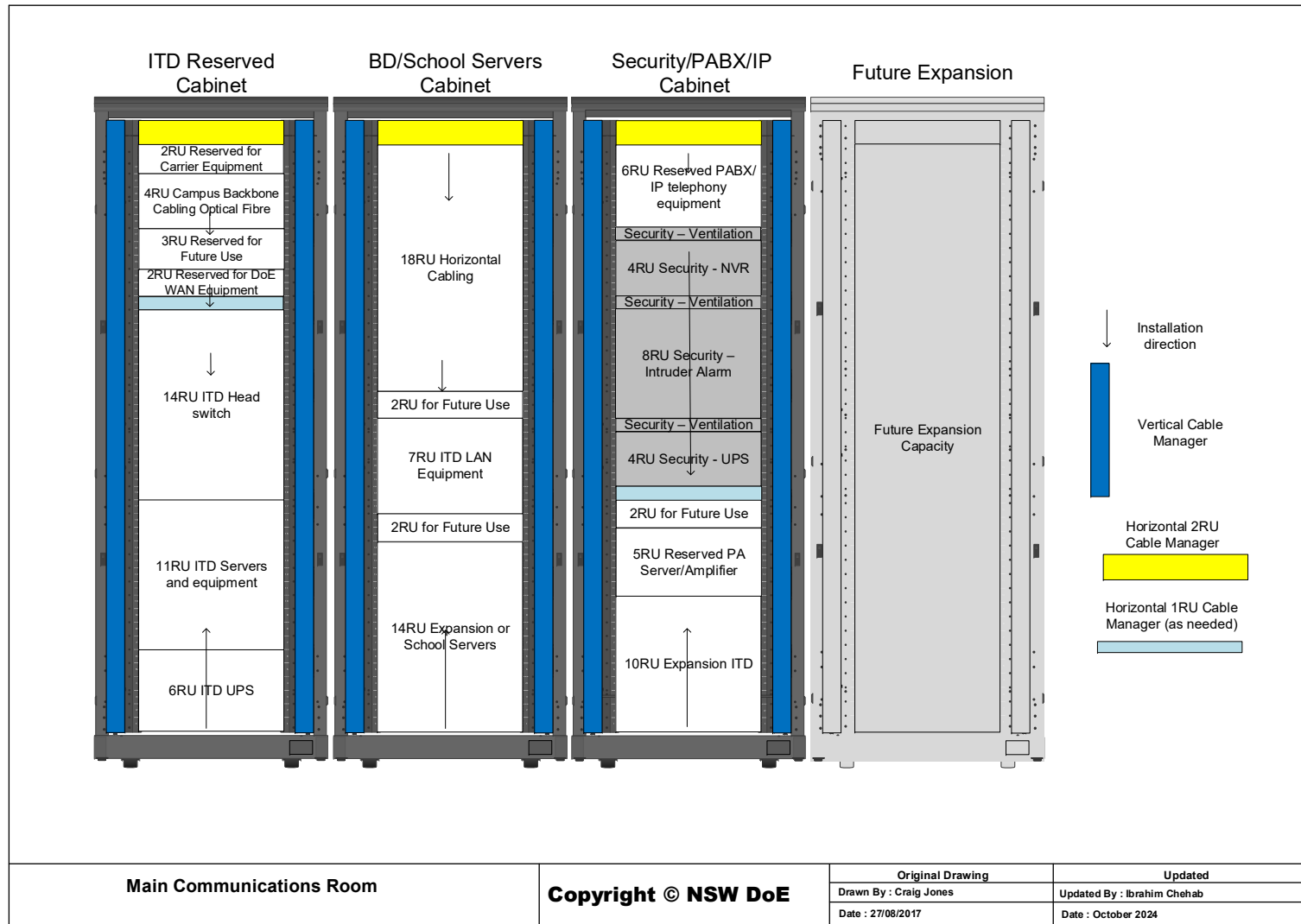

Figure 7 - MCR Rack Layout

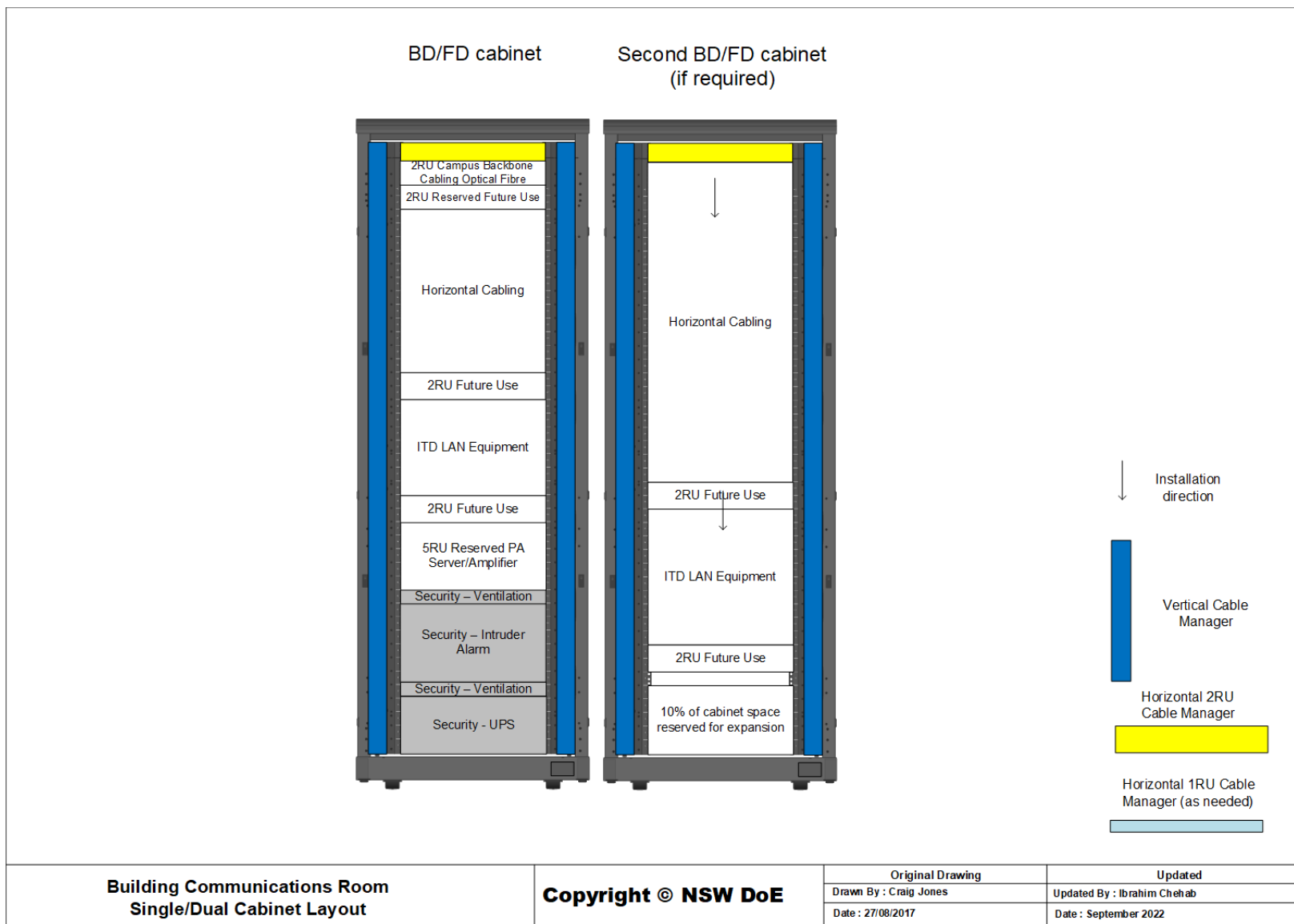
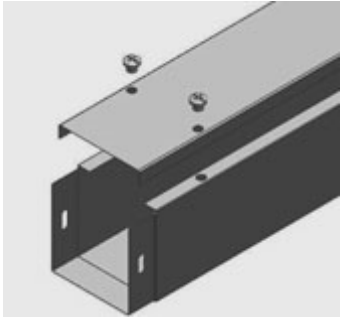
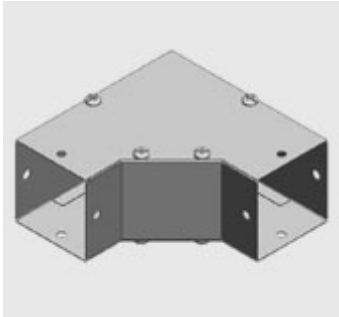





Figure 8 - BCR Single/Dual Rack Layout

## Appendix C. Pathway materials and fixings

Item	Description	Picture	
Trunking PVC 25 X 25mm 4mtr WHITE	Permanent Outlet Pathway		
Trunking PVC 100 x 50mm	Local Distribution Pathway		
Mesh Cable tray Enclosed Trunking (in exposed areas)	Horizontal Cabling Pathway	 <p data-bbox="587 1061 778 1093">Mesh cable tray</p>	 <p data-bbox="992 1061 1359 1115">Enclosed trunking (in exposed areas)</p>
Cable bend radius compliant waterfall	Horizontal Cabling Pathway		
Metal Cable Tray + Lid	Building Backbone Pathways	 <p data-bbox="676 1787 880 1818">Metal cable tray</p>	 <p data-bbox="1171 1787 1216 1818">Lid</p>

Item	Description	Picture	
Metal Duct	Building Backbone Pathways		
Raceway	For fibre and copper connections between cabinets in the same room	 	
Hook & Loop Straps	Reusable Cable support		

## Appendix D: Fibre examples

### Fibre Enclosures



Figure 9 - Example of a high-density fibre enclosure

### Fibre connections and patch leads

Single-Mode: OS1/OS2.

Patch leads shall be “YELLOW” with connectors or strain relief/mating adaptor shall be “BLUE”



Figure 10 - Yellow patch lead with blue strain relief/mating adaptor

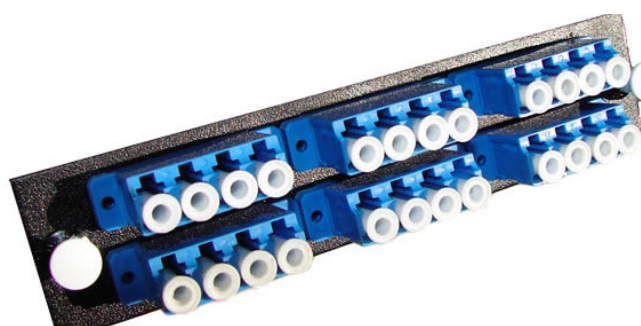

Figure 11 – Fibre adaptor panel

## Appendix E: External WAP

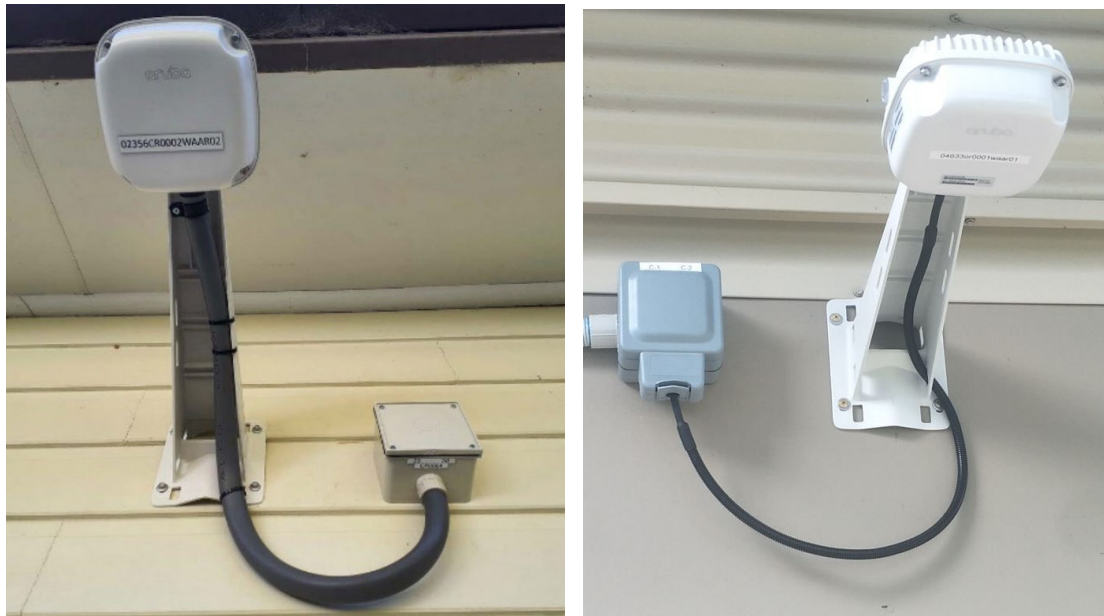

Figure 12 - External WAP installation ref. 1 (Note use of the waterproof cover and labelling)



Figure 13 - External WAP installation ref. 2 (Note use of BSP fitting for cable ingress to WAP)



*Figure 14 - Wireless bridge installation ref. 3 - BSP fitting and water proofing need to be followed as per instructions*

## Appendix F: Patch cable colour chart

Device	Patch Panel End		Device End	
	Colour	AWG	Colour	AWG
Workstations, printers	Blue	26	N/A	26
VOIP Controller, dedicated VOIP handsets	Black	26	N/A	26
Digital/Analog handsets	Beige	26	N/A	26
Wireless Access Point	White	26	White	26
Security devices (CCTV, Access control etc.)	Red	26	Red	26
BMS devices (Solar, Environmental etc.)	Grey	26	N/A	26
Audio-visual	Purple	26	N/A	26
Switch uplinks (DAC cables exempted)	Pink	26	N/A	N/A
Carrier NTU to DoE WAN device	Yellow	26	N/A	N/A
DoE WAN device to Core Switch	Green	26	N/A	N/A

## Appendix G: Conduit and pit diagrams

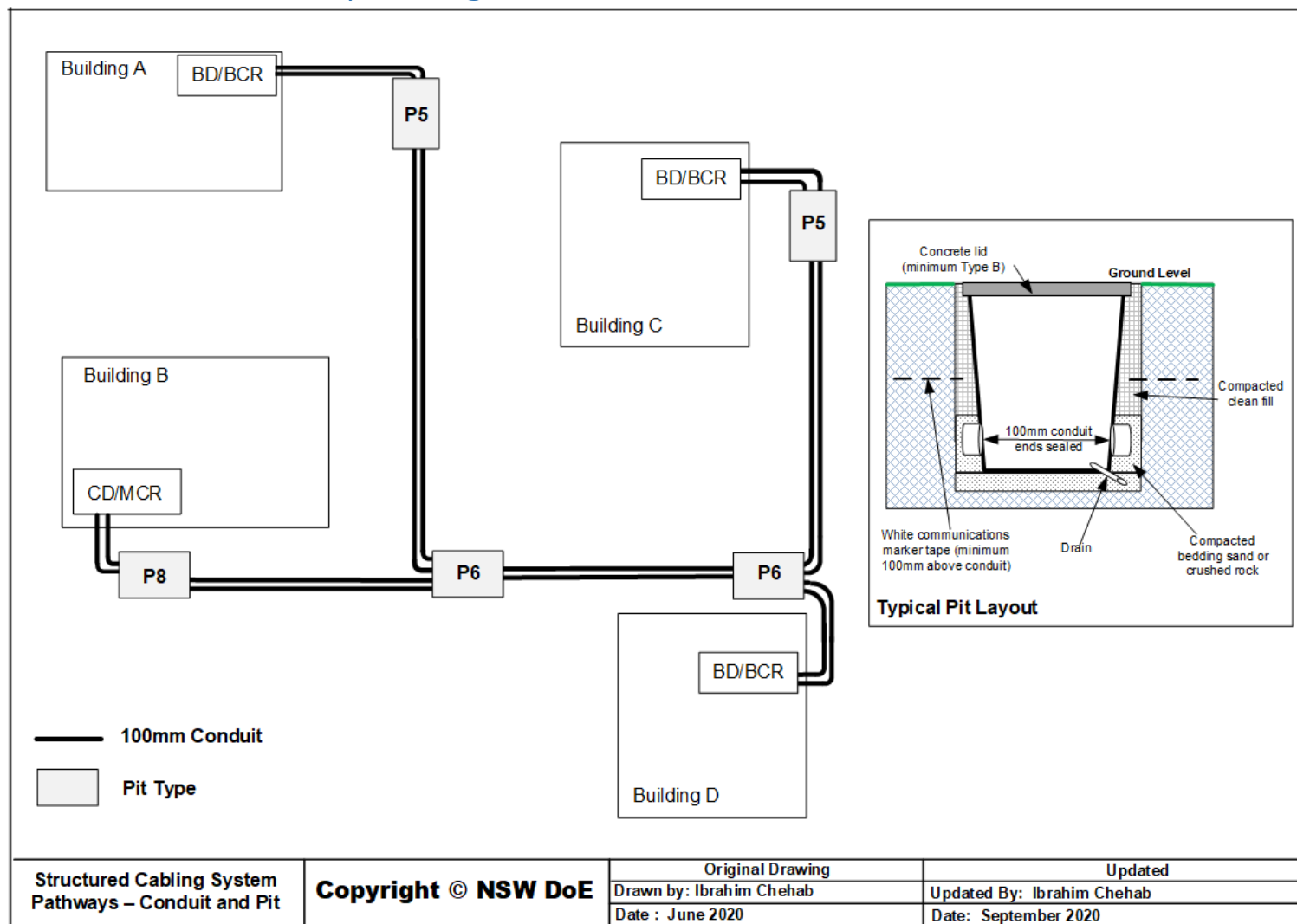
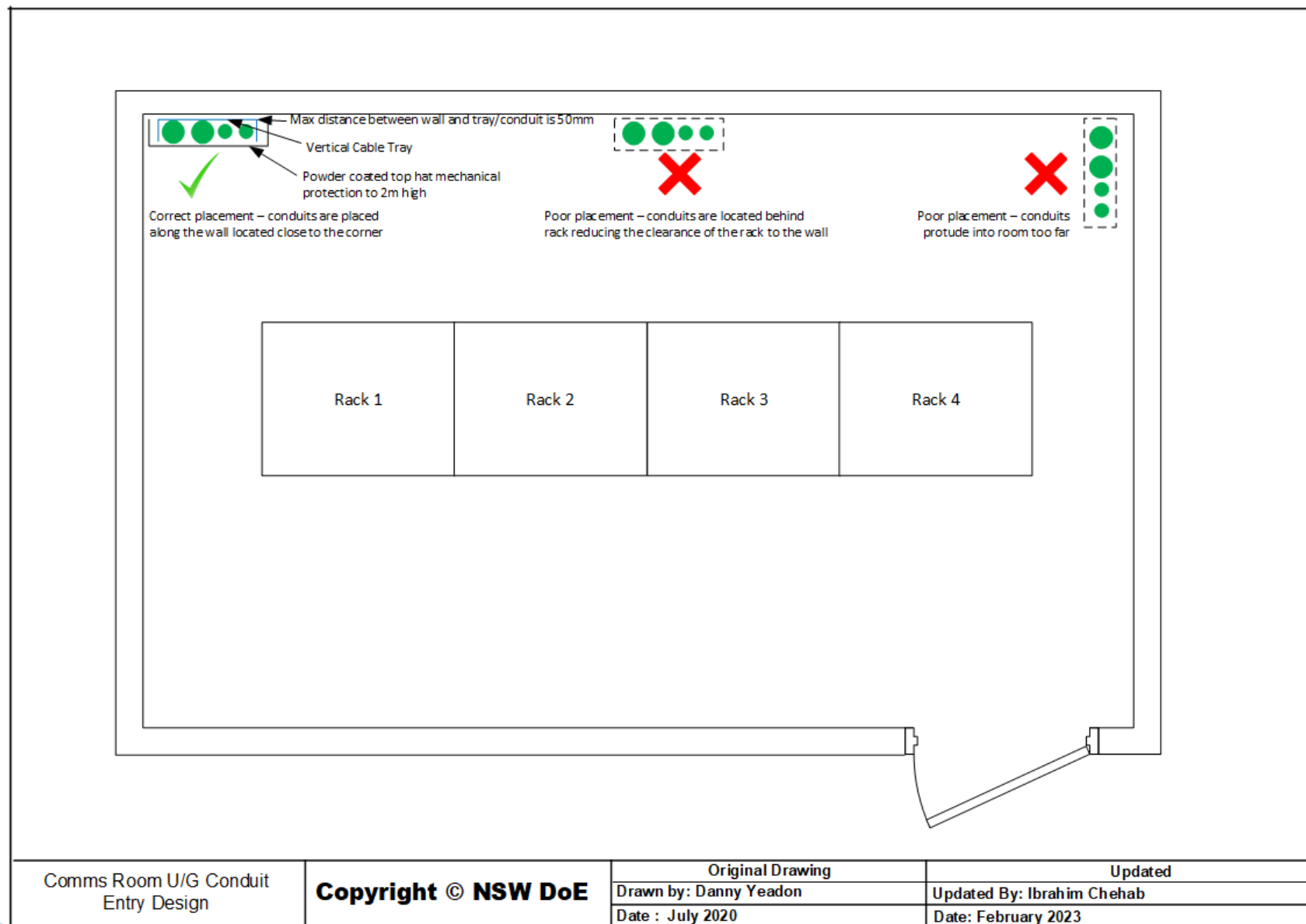

Figure 15 - Conduit and Pit Diagrams



## Appendix H: Equipment Sample Approval (ESA) Form

Number		ABC001	
<b>SUBCONTRACTOR TO COMPLETE</b>			
Subcontractor company name		Cabling4U Pty Ltd	
Subcontractor contact name		John Smith	
Subcontractor contact phone number		1234 5678	
Site installation Name		Test School	
Site Code (4 digit)		9999	
Location to be Installed (buildings, rooms)		Blocks A, B and C	
Item Description		Cat6A shielded jack	
Product Model No. (specific part number)		CJSH6X88TGY-TX6A	
Specification Reference		Department of Education, NSW Structured Cabling System Specifications 2020	
Supplied as specified [Y]/[N] Alternate Solution		Y	
Sample Information Provided	Physical Sample		
	Tech Data Sheet/Product Manual	Y	Spec sheet attached
	Certificates		
	Shop Drawings		
	Other		
<b>Consultant endorsement</b>			
		Name	Signature
Electrical/Data (If Applicable)			
<input type="checkbox"/>	Approved	Comments:	
<input type="checkbox"/>	Approved with Comments		
<input type="checkbox"/>	Resubmit as per comments		
<input type="checkbox"/>	Rejected		
<b>Client endorsement</b>			
		Name	Signature
School Network Solution Design Authority (Required)		John Smith	24/07/2020
X	Approved	Comments:	
<input type="checkbox"/>	Approved with Comments		
<input type="checkbox"/>	Resubmit as per comments		
<input type="checkbox"/>	Rejected		
Foundations.T4L (Required)		John Doe	24/07/2020
X	Approved	Comments:	

	Approved with Comments	
	Resubmit as per comments	
	Rejected	

## Appendix I: Cabling Checklist

### Pre-Installation Checklist

<b>Cabling Contractor Details:</b>			
<b>DoE Project Manager:</b>			
<b>ICT Team Leader:</b>			
<b>SCSS Version:</b>			
Item No	Description	Y / N or N/A	Comments
1	<b>General</b>		
1.1	Cabling Contractor is SCM0020 certified		
1.2	Cabling Contractor is accredited with the cable manufacturer as an approved Installer		
1.3	Cabling Contractor and the person(s) working on the cable plant have the required ACMA endorsements		
1.4	Cabling plans/drawings have been agreed to by all parties		
1.5	List of materials and fixings have been provided and approved		
1.6	Cabling contractor has read and agrees to abide by the SCSS		
1.7	Cabling contractor acknowledges the post-installation checklist		
1.8	Pre rough-in meeting arranged with ICT Team Leader		Date:

### Post-Installation Checklist

<b>School Name:</b>		<b>Address:</b>	
<b>Project Name:</b>		<b>Date:</b>	
<b>Cabling Contractor Details:</b>			
<b>DoE Project Manager:</b>		<b>SCSS Version:</b>	
<b>Checked By:</b>		<b>Signature:</b>	

Item No	Description	Y / N or N/A	Comments
2	<b>Communications Rooms</b>		
2.1	MCR meets room dimensions as per SCSS and EFSG		
2.2	MCR/BCR is located in a suitable area		
2.3	MCR has air conditioning		

2.4	BCR has adequate cooling		
2.5	Comms rooms contain only IT related equipment		
2.6	Comms rooms have adequately sized doors		
2.7	Comms rooms have adequate access leading to it		
2.8	Comms room has a minimum DTO installed		
2.9	Comms rooms are adequately secured (i.e lock, swipe card)		
2.10	Comms rooms are clean and dust free		
<b>3</b>	<b>Racks/Data Cabinets</b>		
3.1	Racks in MCR meet spec (45RUx800x1000)		
3.2	Racks in BCR meet spec (45RUx800x800)		
3.3	Racks are all-metal construction		
3.4	Racks are installed properly		
3.5	Each rack has 2 x vertical cable managers		
3.6	Racks have adequate horizontal cable managers		
3.7	Each rack has 2 x dedicated 15Amp captive pendants above		
3.8	10 way vertical PDU installed in each MCR rack		
3.9	Each rack contains a shelf		
3.10	Racks are bonded to protective earth		
3.11	All racks doors and side panels are key lockable		
3.12	Rack doors are meshed		
3.13	All racks have RU markings front and back		
3.14	All racks are labelled as per the SCSS		
3.15	Front and rear rails are 'L shaped profile and are adjustable		
3.16	Racks in MCR have a raceway installed between them and it is attached to the same supports as the in room ceiling suspended cable tray		
3.17	All cabling enters from the top of the rack		
<b>4</b>	<b>Pathways</b>		
4.1	Different pathways are used for structured cabling and electrical wiring		
4.2	Pathway is accessible throughout its length		
4.3	Cable trays are used where there is 10 or more cables		
4.4	Cable trays are adequately suspended		
4.5	Cable trays have no sharp edges		
4.6	Cable trays have adequate waterfall and bend components		
4.7	Estimated pathway fill is less than 40%		
4.8	Cables are adequately secured onto cable trays		

4.9	Velcro is used and not plastic tie cables		
4.10	Catenary wire has less than 10 cables		
4.11	Catenary wire is adequately secured		
4.12	Pit(s) installed are of adequate size as per SCSS		
4.13	Lids are of appropriate load rating		
4.14	All pits and cables are labelled as per the SCS		
<b>5</b>	<b>Fibre</b>		
5.1	Minimum of 12 core single-mode fibre is installed per BCR		
5.2	All fibres are terminated		
5.3	FOBOT is placed at the top of the cabinet		
5.4	Unused ports on FOBOT have cap covers		
5.5	Ports on FOBOT are labelled accordingly		
5.6	Fibre cable and components all belong to the same mode		
5.7	No visible kinks, crushed and tight bends in the cable		
5.8	The fibre cable leading into the FOBOT is labelled as per the SCSS		
5.9	The FOBOT is labelled as per the SCSS		
5.10	Fibre patch leads are of adequate number and length		
5.11	Spare fibre patch leads are available		
<b>6</b>	<b>4-Pair Copper Cabling</b>		
6.1	Cable is Low Smoke Zero Halogen (LSZH)		
6.1	Patch panels, patch cords and jacks used all match the category and construction of the cable installed		
6.2	Patch panels, patch cords and jacks used are all from the same manufacturer		
6.3	No visible kinks, crushed and tight bends in the cable		
6.4	Cables terminated into the rack are done in a neat fashion		
6.5	All cabling is more than 300mm away from power cabling		
6.6	All cabling enters through the roof space and into the designated roof corner of the cabinet		
6.7	24 port 1RU patch panels are used		
6.8	All cables are installed with unique outlet numbering sequence that is continuous across the entire installation		
6.9	No more than 24 cables in a bundle when in a cable tray or in the cabinet		
6.10	If shielded cable is used, then all components (cable, patch panel, rack etc.) are earthed as per the manufacturers recommendation		
6.11	Labelling of the patch panel is done as per the SCSS		

6.12	Telecommunications Outlets are installed in a appropriate location and at an acceptable height		
6.13	Telecommunication outlets have spring-loaded shutters		
6.14	Telecommunication outlets require a tool in order to get to the jack or labelling		
6.15	Telecommunication Outlet has adequate slack		
6.16	All ports in the patch panel are patched in a neat manner and are using the supplied cable managers		
6.17	Patch cables used are of adequate gauge size and match the colour patch guide		
6.18	External copper runs use external rated cables		
6.19	Surge protection installed at the distributor end for each external rated copper cable		
<b>7</b>	<b>Documentation</b>		
7.1	Fibre Optic Test results provided to DoE as per SCSS		
7.2	4-Pair UTP Test results provided to DoE as per SCSS		
7.3	Cable pathway diagrams provided by the contractor to DoE showing pits, risers, cable trays etc.		
7.4	Floor plans showing outlet locations and their associated identifier provided to DoE by the cabling contractor		
7.5	Patch records for each comms rack is provided		
7.6	Manufacturer's warranty certificate provided to DoE by the cabling contractor		
7.7	TCA-1 and/or TCA-2 form provided to the DoE project manager or ICT team leader		